



TWS COBRA

Reservdelista

TWS

04-1300

CONTENTS

Fig.1	CYLINDER HEAD.....	2
Fig.2	CRANKSHAFT.....	3
Fig.3	FAN COVER.....	4
Fig.4	OIL PUMP ASS'Y.....	5
Fig.5	AIR CLEANER.....	6
Fig.6	CARBURETOR.....	7
Fig.7	EXHAUST PIPE.....	9
Fig.8	CRANKCASE.....	10
Fig.9	STARTER.....	12
Fig.10	DRIVE PULLEY.....	14
Fig.11	DRIVE SHAFT.....	16
Fig.12	ENGINE BRACKET.....	17
Fig.13	FRAME BODY.....	18
Fig.14	SWING ARM,FOOTREST,FEND BAR.....	19
Fig.15	FENDER.....	21
Fig.16	SEAT.....	22
Fig.17	OIL TANK, FUEL TANK.....	23
Fig.18	SUSPENSION.....	24
Fig.19	FRONT WHEEL.....	25
Fig.20	REAR WHEEL.....	26
Fig.21	FRONT BRAKE.....	27
Fig.22	REAR BRAKE.....	28
Fig.23	HANDLE BAR.....	30
Fig.24	REAR WHEEL AXLE.....	32
Fig.25	CHAIN.....	33
Fig.26	STEERING.....	34
Fig.27	FRONT HEAD LIGHT, TAIL LIGHT.....	35
Fig.28	GENERATOR, START MOTOR.....	36
Fig.29	ELECTRICAL PARTS.....	37
Fig.30	DECALS.....	38
Fig.31	STANDARD ACCESSORY	39

D-1 CYLINDER HEAD (50 cc)

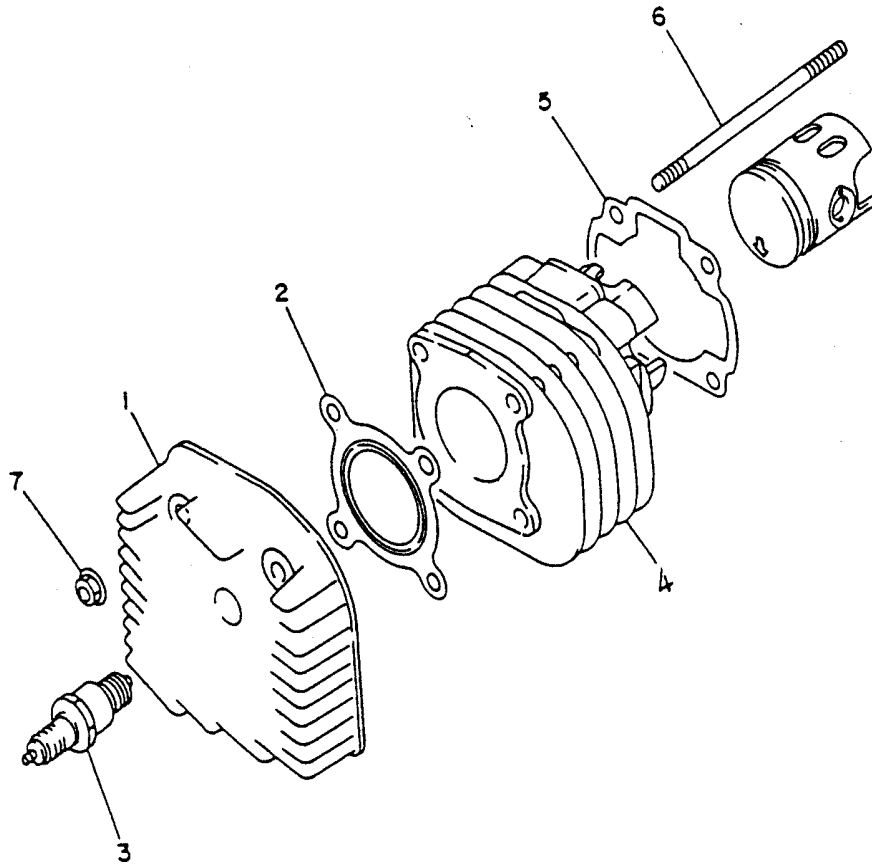

P/N	DESCRIPTION	PART NO.		Q'TY	REMARK
1-1	CYLINDER HEAD	12201-113-000		1	
1-2	CYLINDER HEAD GASKET	12251-113-000		1	
1-3	SPARK PLUG	98076-111-00A		1	BP7HS
1-4	CYLINDER	12101-113-000		1	
1-5	CYLINDER GASKET	12191-113-000		1	
1-6	STUD BOLT	91001-07110-C		4	M7×110
1-7	HEX FLANGE NUT SERPATION	94050-07000-C		4	M7

D-2 CRANKSHAFT (50 cc)

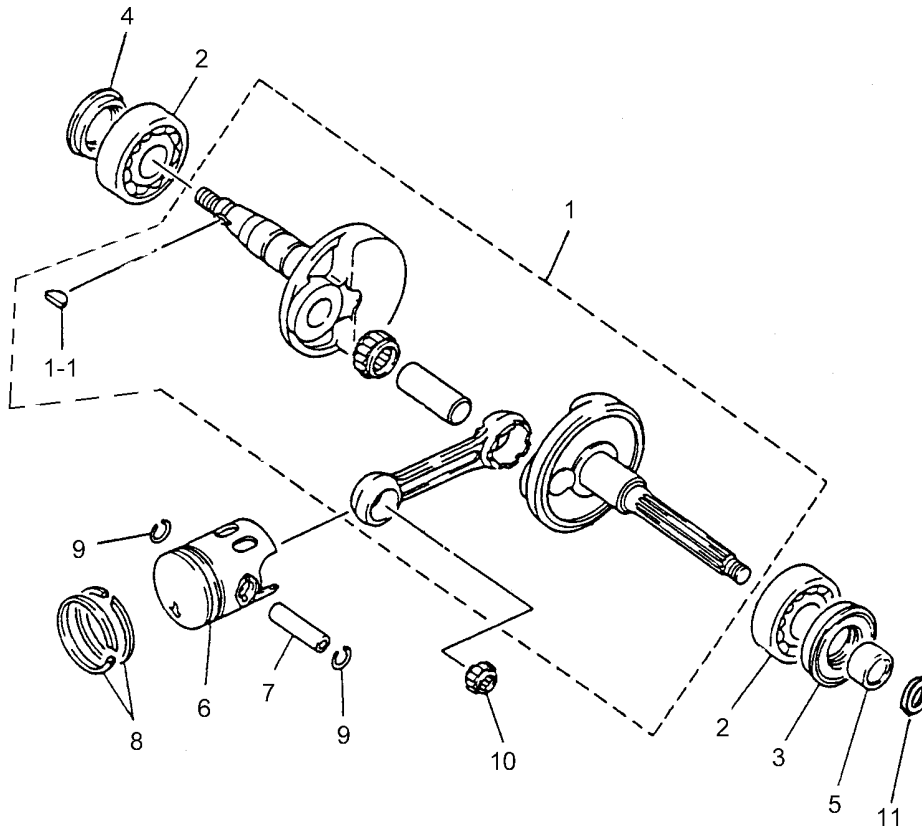

P/N	DESCRIPTION	PART NO.		Q'TY	REMARK
2-1	CRANKSHAFT	13000-113-000		1	
2-1-1	SEMICYCLE KEY	90471-111-000		1	3×13
2-2	RADIAL BALL BEARING	96100-62040		2	6204C3
2-3	OIL SEAL	96500-20428		1	20×42×8
2-4	OIL SEAL	96500-20306		1	20×30×6
2-5	LEFT CREANK COLLER	13316-113-000		1	15.1×20×12
2-6	PISTON	13100-111-000		1	
2-7	PISTON PIN	13111-111-000		1	
2-8	PISTON RING SET	13011-111-000		2	
2-9	PISTON PIN CLIP	13115-111-000		2	
2-10	NEEDLE BEARING	96200-101412		1	10×14×12.5
2-11	PLAIN WASHER	94101-1319005		1	13×19×0.5

D-3 FAN COVER (50 cc)

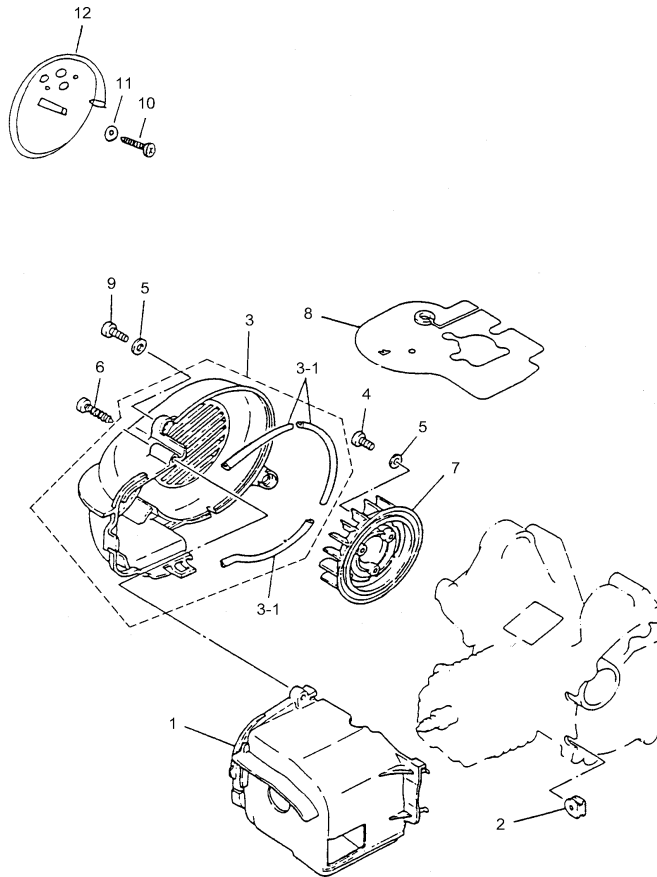

P/N	DESCRIPTION	PART NO.		Q'TY	REMARK
3-1	CYLINDER AIR SHROUD	19620-151-000		1	
3-2	CYLINDER GROMMET	83552-113-000		2	
3-3	FAN COVER	19610-151-000		1	
3-3-1	AIR SHROUD DAMPER	17632-113-000		3	
3-4	HEX SOCKET BOLT	91000-06016-K		3	M6×16
3-5	PLAIN WASHER	94101-0613010-C		5	6×13×1
3-6	TAPPING SCREW	93903-05040-K		1	M5×40
3-7	FAN	19510-113-000		1	
3-8	DEFLECTOR	55122-113-000		1	
3-9	HEX SOCKET BOLT	91000-06020-C		2	M6×20
3-10	TAPPING SCREW	93903-05016-K		1	M5×16
3-11	PLAIN WASHER	94101-0619010-C		1	6×19×1
3-12	FAN DUST COVER	19600-131-W038		1	

D-4 OIL PUMP ASS'Y (50cc)

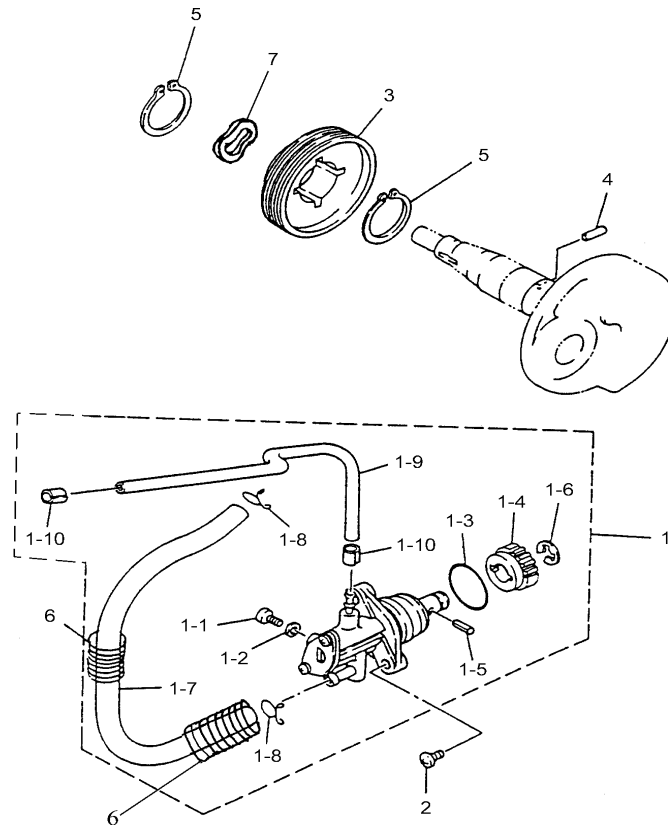

P/N	DESCRIPTION	PART NO.	Q'TY	REMARK
4-1	OIL PUMP ASS'Y	15100-131-001	1	L=540mm
4-1-1	PAN PHILLIPS BOLT	93500-04016	1	M4×16
4-1-2	WASHER	94101-0408505	1	4×8.5×0.5
4-1-3	O-RING	91319-113-000	1	
4-1-4	OIL PUMP WORMWHEEL	15136-113-000	1	
4-1-5	SHAFT PIN	96300-030130	1	3×13
4-1-6	EXTERNAL CIR CLIP	94511-0700E	1	ETW-7
4-1-7	OIL TUBE	94400-04808	1	4.8×8×540
4-1-8	OLIP	94510-08000	2	8×0.8
4-1-9	OIL TUBE	94400-02005	1	2×5
4-1-10	CLIP	95510-05000	2	
4-2	PAN PHILLIPS BOLT	93500-05014-C	2	M5×14
4-3	OIL PUMP DRIVE GEAR	15150-111-000	1	
4-4	DOWEL PIN	96300-030118	1	NR3×11.8
4-5	EXTERNAL CIR CLIP	94511-1900S	2	S-19
4-6	OIL PIPE PROTECTIVE SPRING	15311-113-000	2	
4-7	WAVE WASHER	15151-111-000-K	1	19×26×0.3

D-5 AIR CLEANER (50cc)

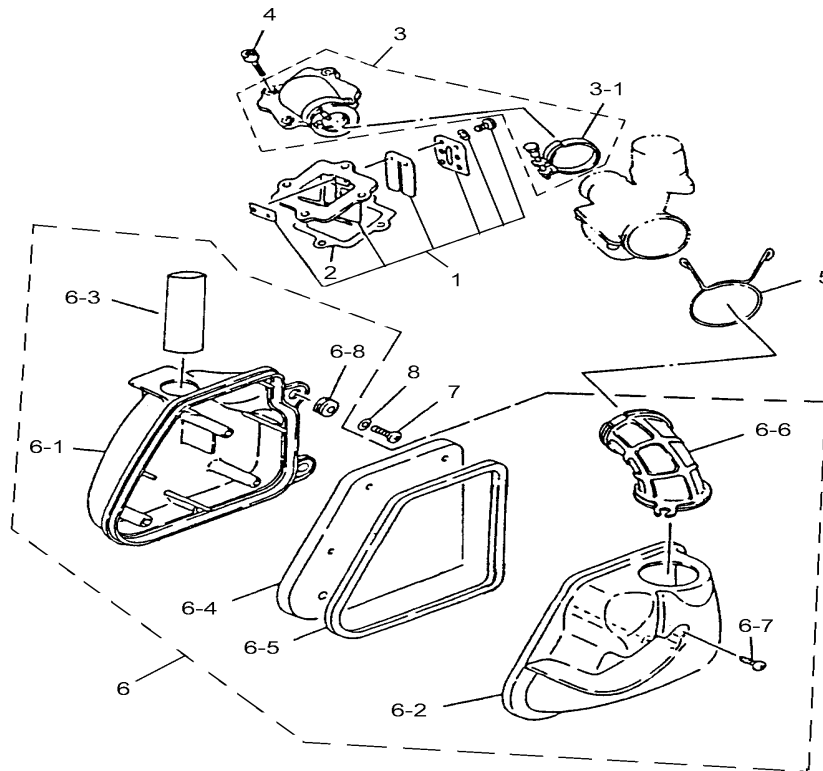

P/N	DESCRIPTION	PART NO.	Q'TY	REMARK
5-1	REED VALVE ASS'Y	14100-113-000	1	
5-2	GASKET	17111-113-000	1	
5-3	INTAKE MANIFOLD	17100-113-000	1	
5-3-1	INTAKE MANIFOLD HOSE CLAMP	14110-113-000	1	
5-4	HEX WASHER FACE BOLT	96000-06018-08-C	4	M6×18
5-5	CLIP	94510-40000	1	40×2.3
5-6	AIR CLEANER COMP	17200-131-000	1	
5-6-1	AIR CLEANER CASE	17206-113-000	1	
5-6-2	AIR CLEANER CASE CAP	17207-113-000	1	
5-6-3	CLEANER GUIDE PIPE	17219-131-000	1	
5-6-4	AIR CLEANER ELEMENT	17205-113-000	1	
5-6-5	SEAL	17212-113-000	1	
5-6-6	AIR CLEANER JOINT	17253-113-000	1	
5-6-7	TAPPING SCREW	93903-05026	3	5×26
5-6-8	GROMMET	96485-113-000	2	
5-7	HEX SOCKET BOLT	91000-06020-C	2	M6×20
5-8	PLAIN WASHER	94101-0613010-C	2	6×13×1

D-6 CARBURETOR (50 cc)

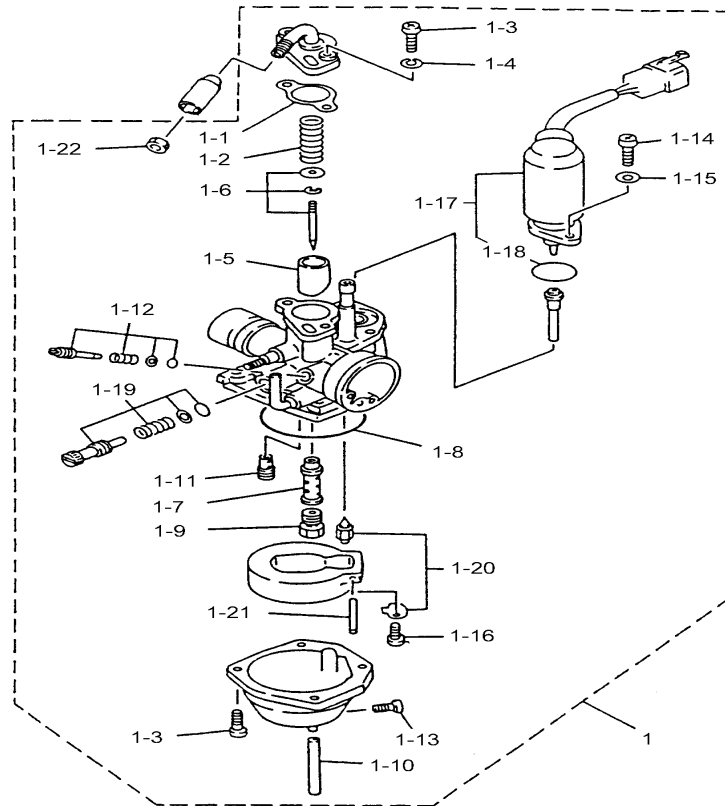

P/N	DESCRIPTION	PART NO.		Q'TY	REMARK
6-1	CARBURETOR ASS'Y	16100-113-000		1	
6-1-1	GASKET	16101-113-000		1	
6-1-2	THROTTLE STOP SPRING	16102-113-000		1	
6-1-3	PAN PHILLIPS BOLT	93500-04014		6	M4×14
6-1-4	PLAIN WASHER	94111-0407010		2	
6-1-5	THROTTLE VALVE	16103-113-000		1	
6-1-6	NEDDLE SET	16104-113-000		1	
6-1-7	NEDDLE NOZZLE	16105-113-000		1	
6-1-8	FLOAT CHANBER SEAL	16106-113-000		1	
6-1-9	MAIN NOZZLE	16108-113-000		1	MJ:75
6-1-10	OVER FLOW YUBE	16109-113-000		1	
6-1-11	PILOT JET	16110-113-000		1	
6-1-12	AIR ADJUST SCREW SET	16115-113-000		1	
6-1-13	DRAIN PLUG	16111-113-000		1	
6-1-14	PAN PHILLIPS BOLT	93500-04008		2	M4×8
6-1-15	PLAIN WASHER	94111-0406510		2	4×6.5×1
6-1-16	PAN PHILLIPS BOLT	93500-03006		1	M3×6
6-1-17	STARER PLUNGER	17215-113-000		1	
6-1-18	OIL RING	91314-113-000		1	14×1.5
6-1-19	THROTTLE SCREW SET	16114-113-000		1	
6-1-20	NEDDLE VALVE SET	16117-113-000		1	
6-1-21	FLOAT PIN	16119-113-000		1	
6-1-22	CABLE ADJUST NUT	16113-113-000		1	

D-7 EXHAUST PIPE (50cc)

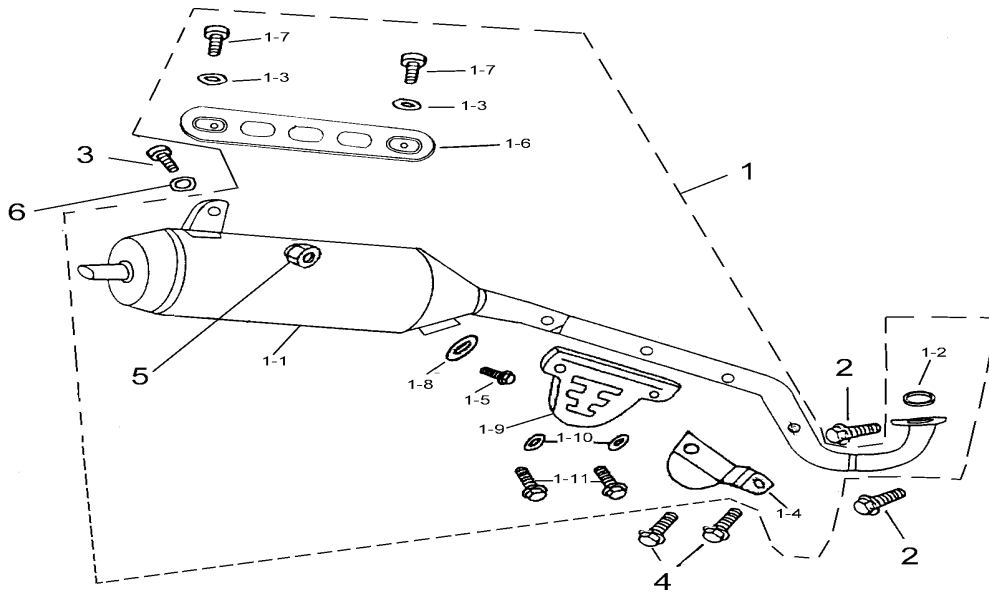

P/N	DESCRIPTION	PART NO.		Q'TY	REMARK
7-1	EXHAUST PIPE ASS'Y	18300-151-000		1	
7-1-1	EXHAUST PIPE	18301-151-000		1	
7-1-2	EXHAUST PIPE GASKET	18291-111-000		1	25.4×34×4
7-1-3	GASKET	94102-0613010		2	6×13×1.0
7-1-4	EXHAUST PIPE FIX PLATE	18317-131-000		1	
7-1-5	HEX WASHER FACE BOLT	96000-08012-K		3	M8×12
7-1-6	PROTECTOR	18318-131-000		1	
7-1-7	PAN PHILLIPS BOLT	93500-06009-B		2	M6×9
7-1-8	GASKET	94102-0813010		1	8×13×1.0
7-1-9	EXHAUST PIPE PROTECTOR	18315-131-000		1	
7-1-10	GASKET	94102-0613010		4	6×13×1.0
7-1-11	PAN PHILLIPS BOLT	93500-060010		2	M6×10
7-2	HEX WASHER FACE BOLT	96000-06018-CT		2	M6×18
7-3	HEX WASHER FACE BOLT	96000-08035-K		1	M8×35+
7-4	HEX WASHER FACE BOLT	96000-08012-K		2	M8×12
7-5	HEX WASHER FACE NYLON NUT	90350-08000-UK		1	M8
7-6	PLAIN WASHER	94101-1022020-C		1	10×22×2

D-8 CRANKCASE (50 cc)

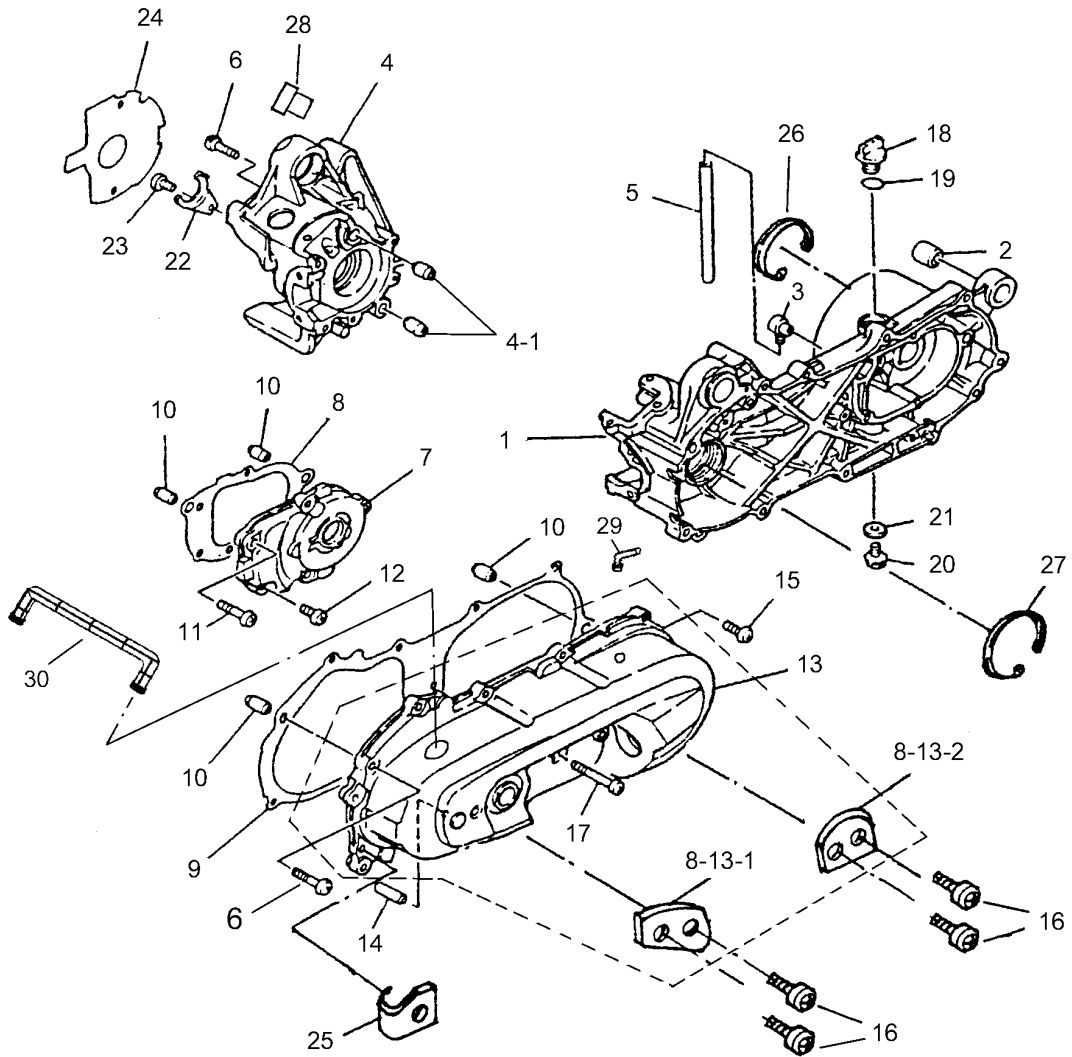

P/N	DESCRIPTION	PART NO.	Q"TY	REMARK
8-1	LEFT CRANKCASE	11201-131-000	1	
8-2	RUBBER BUSHING	96400-082020	1	
8-3	BREATHER HOSE HEAD	16610-113-000	1	
8-4	RIGHT CRANKCASE	11101-131-000	1	
8-4-1	DOWEL PIN	94301-12160	2	12×16
8-5	BREATHER HOSE	16615-113-000	1	L=70mm
8-6	HEX SOCKET BOLT	91000-06035-K	8	M6×35
8-7	MISSION COVER	21301-113-000	1	
8-8	MISSION COVER GASKET	21395-113-000	1	

8-9	LEFT CRANKCASE COVER GASKET	11359-113-000		1	
8-10	DOWEL PIN	94301-10140		4	10×14
8-11	PAN SOCKET BOLT	91000-06030-K		2	M6×30
8-12	PAN SOCKET BOLT	91000-06020-C		3	M6×20
8-13	LEFT CRANKCASE COVER	11341-151-000		1	
8-13-1	PROTECTOR A	11343-113-000		1	
8-13-2	PROTECTOR B	11344-113-000		1	
8-14	SHAFT	96300-080290		1	8×29
8-15	HEX SOCKET BOLT	91000-06025-K		8	M6×25
8-16	PAN PHILLIPS BOLT	93500-05010-K		4	M5×10
8-17	HEX SOCKET BOLT	91000-06060-K		1	M6×60
8-18	OIL PULG	15650-111-000		1	M14×1.5×15L
8-19	O-RING	91312-111-000		1	Ø13.8×2.5
8-20	HEX WASER FACE BOLT	96000-08016-K		1	M8×16
8-21	PLAIN WASHER	94101-0815012		1	8.2×15×1.2
8-22	OIL SEAL BRACKET	11111-111-000		1	
8-23	HEX SOCKET BOLT	91000-06010-C		1	M6×10
8-24	GENARATOR GASKET	11121-113-000		1	
8-25	CARBUBETOR TUBE BRACKET	11351-111-000		1	
8-26	INTERNAL CIR CLIP	94512-3200R		1	R-32
8-27	INTERNAL CIR CLIP	94512-4200R		1	R-42
8-28	RUBBER PLUG	12345-111-000		1	
8-29	TUBE BREATHER	11211-112-000		1	
8-30	DUCT	11345-151-000		1	

D-9 STARTER (50 cc)

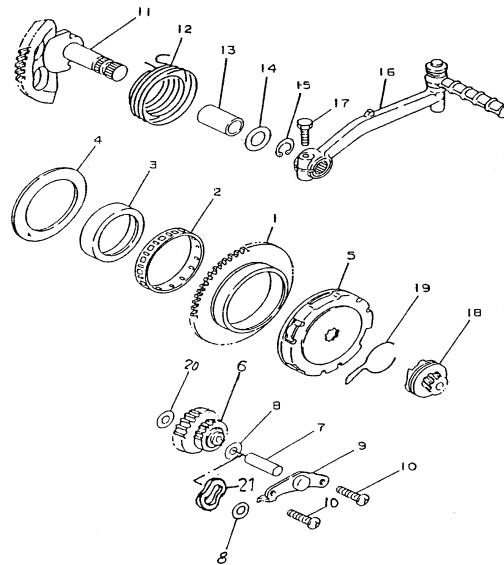

P/N	DESCRIPTION	PART NO.		Q'TY	REMARK
9-1	STARTER WHEEL	28220-117-000		1	68T
9-2	NEEDLE BEARING	96200-555912		1	55×59×12.5
9-3	GEAR BOSS	96202-113-000		1	
9-4	PLAIN WASHER	94101-5676006-C		1	56×76×0.6
9-5	ELECTRIC STARTER CLUTCH SET	28410-113-000		1	
9-6	IDLE GEAR ASS'Y	23422-113-000		1	
9-7	SHAFT	96300-080320		1	8×32
9-8	PLAIN WASHER	94101-0818008-C		2	8.2×18×0.8
9-9	IDLE GEAR PLATE	11206-113-000		1	
9-10	HEX SOCKET BOLT	91000-06012-C		2	M6×12
9-11	KICK SHAFT ASS'Y	28250-113-000		1	
9-12	STARTER SHAFT RESET SPRING	28281-111-000		1	
9-13	BUSHING	96401-152030		1	15×20×30
9-14	PLAIN WASHER	94101-1528010-K		1	15.2×28×1
9-15	EXTERNAL CIR CLIP	94511-1500S		1	S-15
9-16	KICK CRANK ASS'Y	28300-111-000		1	
9-17	HEX WASHER FACE BOLT	96000-06025-K		1	M6×25
9-18	KICK PINION ASS'Y	28230-111-000		1	
9-19	KICK PINION SPRING CLIP	28223-113-000		1	
9-20	PLAIN WASHER	94101-0816015-C		1	8×16×1.5
9-21	WAVE WASHER	15151-113-000-K		1	8.5×12×0.5

D-10 DRIVE PULLEY (50 cc)

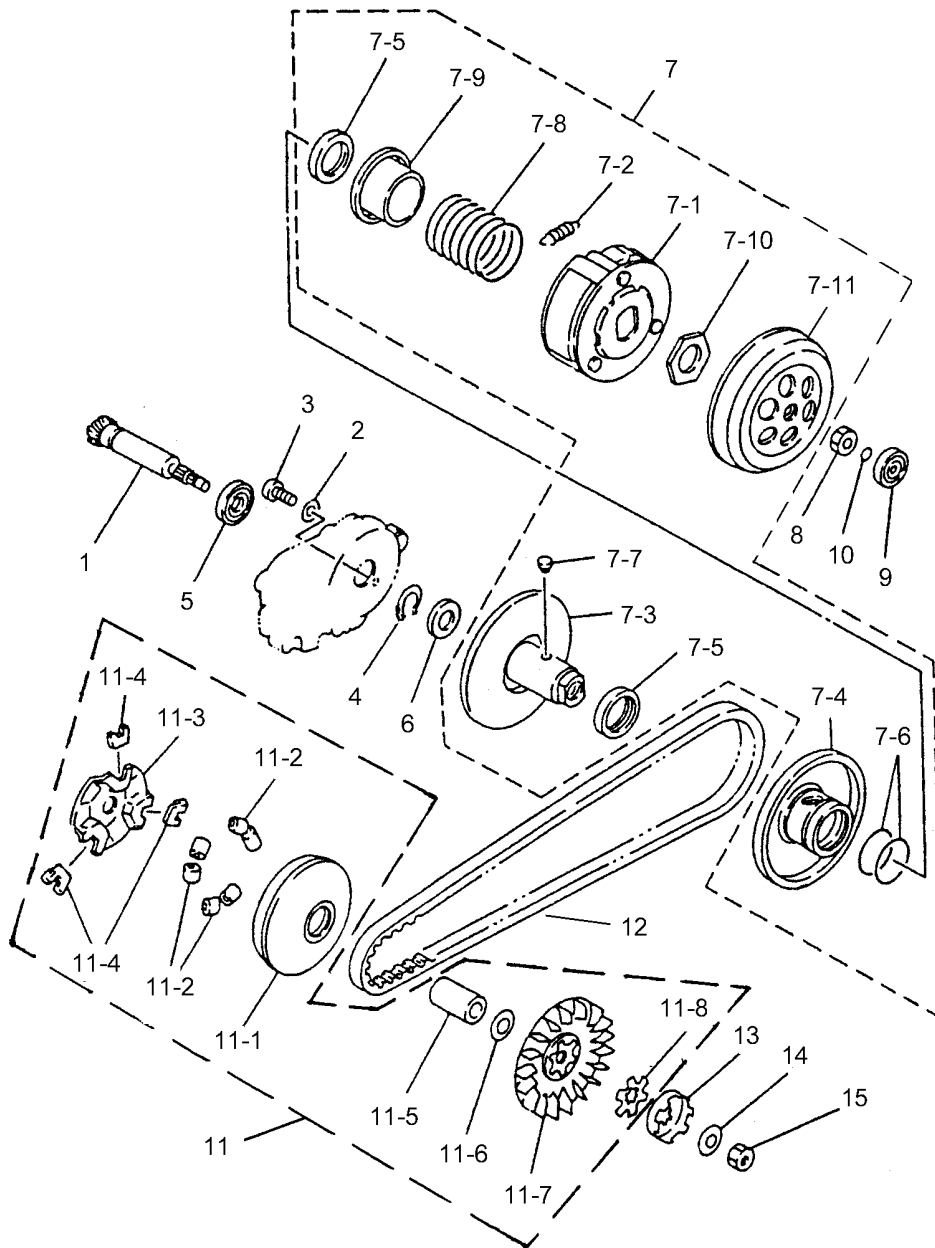

P/N	DESCRIPTION	PART NO.		Q'TY	REMARK
10-1	PRIMARY DRIVE ASS'Y	23411-113-000		1	
10-2	PLAIN WASHER	94101-0619010-C		1	
10-3	HEX. BOCKET BOLT	91000-06010-C		1	M6×10
10-4	EXTERNAL CIR CLIP	94511-1700S		1	S-17
10-5	BEARING	96100-60030		1	6003
10-6	OIL SEAL	96500-17285		1	17×28×5.5
10-7	SECONDARY SHEAVE ASS'Y	22000-113-000		1	
10-7-1	CLUTCH CARRIER	22350-113-000		1	
10-7-2	CLUTCH WEIGHT SPRING	22401-113-000		3	
10-7-3	SECONDARY FIX SLOT WHEEL	23200-113-000		1	
10-7-4	SECONDARY SLIDING SLOT WHEEL	23220-113-000		1	
10-7-5	OIL SEAL	96500-33394		2	33×39×4
10-7-6	OIL RING	91336-113-000		2	36×2
10-7-7	GUIDE PIN	23225-113-000		2	
10-7-8	COMPRESSION SPRING	23233-113-000		1	
10-7-9	SECONDARY SPRING SEAT	23237-113-000		1	
10-7-10	NUT	90202-113-000		1	
10-7-11	CLUTCH COVER COMP	22100-113-000		1	
10-8	HEX NUT	94001-10000-C		1	M10
10-9	BEARING	96100-638ZZ		1	638ZZ
10-10	O-RING	91313-111-000		1	6.5×3
10-11	SLIDING DRIVE FACE ASS'Y	22103-113-000		1	
10-11-1	PRIMARY SLIDING SLOT WHEEL	22110-113-000		1	
10-11-2	WEIGHT ROLLER	22121-113-000		6	
10-11-3	CAM PLATE	22131-113-000		1	
10-11-4	SLIDER	22132-113-000		3	
10-11-5	BUSHING	96401-131838		1	13×18×38
10-11-6	PLAIN WASER	94101-1318010		1	13×18×1
10-11-7	PRIMARY FIX SHEAVE	22102-113-000		1	
10-11-8	CLAW WASHER	22150-111-000		1	
10-12	V-BELT	23100-113-000		1	780-16.5-30
10-13	ONEWAY CLUTCH	22140-111-000		1	
10-14	CONE SPRING WASHER	22145-111-000		1	10.2×24×2.5
10-15	HEX FLANGE NUT WITH SERRATION	94050-10000-C		1	M10

D-11 DRIVE SHAFT (50 cc)

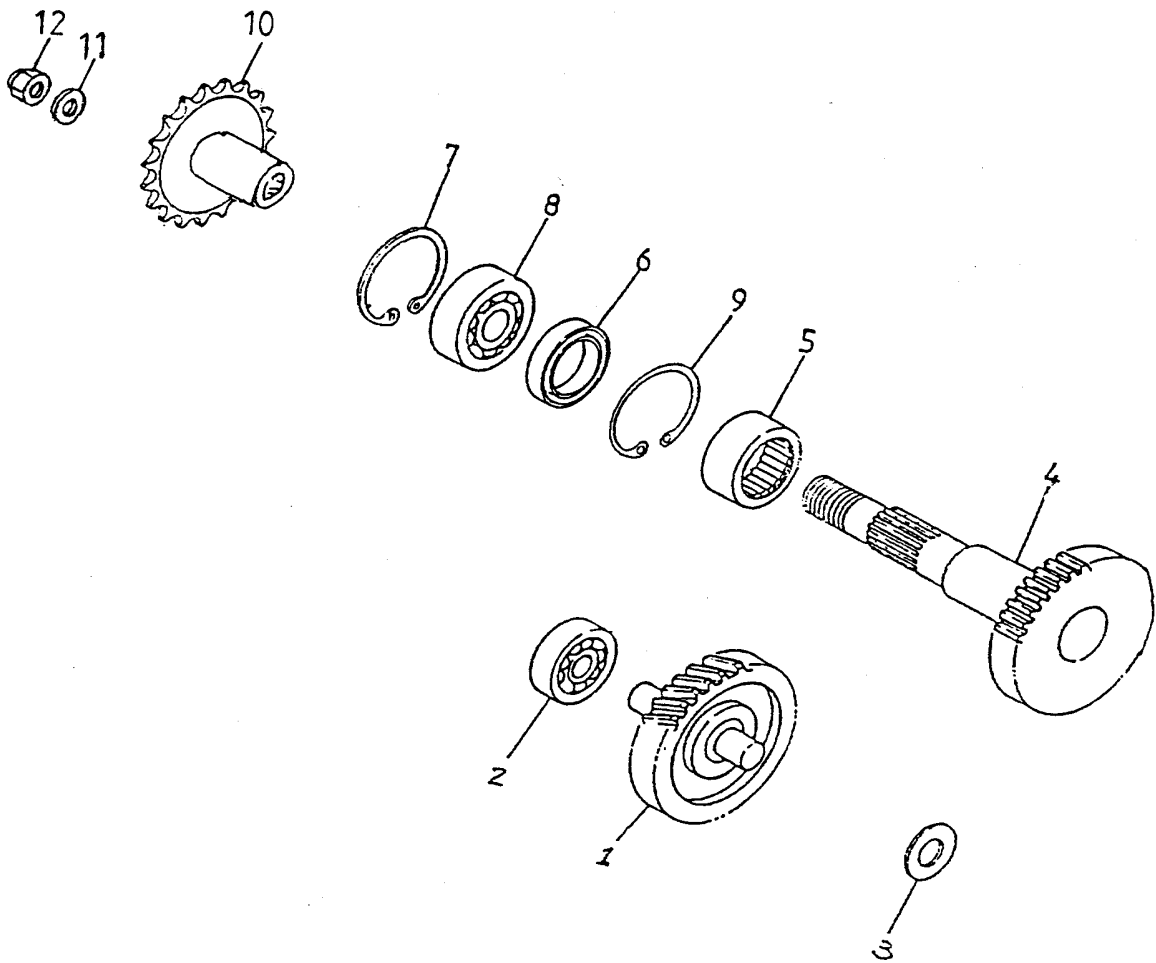

P/N	DESCRIPTION	PART NO.	Q'TY	REMARK
11-1	MAIN AXLE COMP.	23420-113-000	1	
11-2	RADIAL BALL BEARING	96100-62010	1	6201
11-3	PLAIN WASHER	94101-1222010	1	12×22×1
11-4	DRIVE AXLE ASS'Y	23430-113-000	1	
11-5	BEARING	96200-253315	1	2515
11-6	OIL SEAL	96500-25356	1	25×35×6
11-7	CIRCLIP	94512-4200R	1	R-42
11-8	RADIAL BALL BEARING	96100-6004U	1	6004U
11-9	CIRCLIP	94512-3200R	1	R-32
11-10	DRIVE SPOCKET	23801-131-000	1	19T~#428
11-11	PLAIN WASHER	94101-1426020-C	1	14×26×2
11-12	NYLON INSERT LOCK NUT	90350-14000-C	1	M14

D-12 ENGINE BRACKET (50cc)

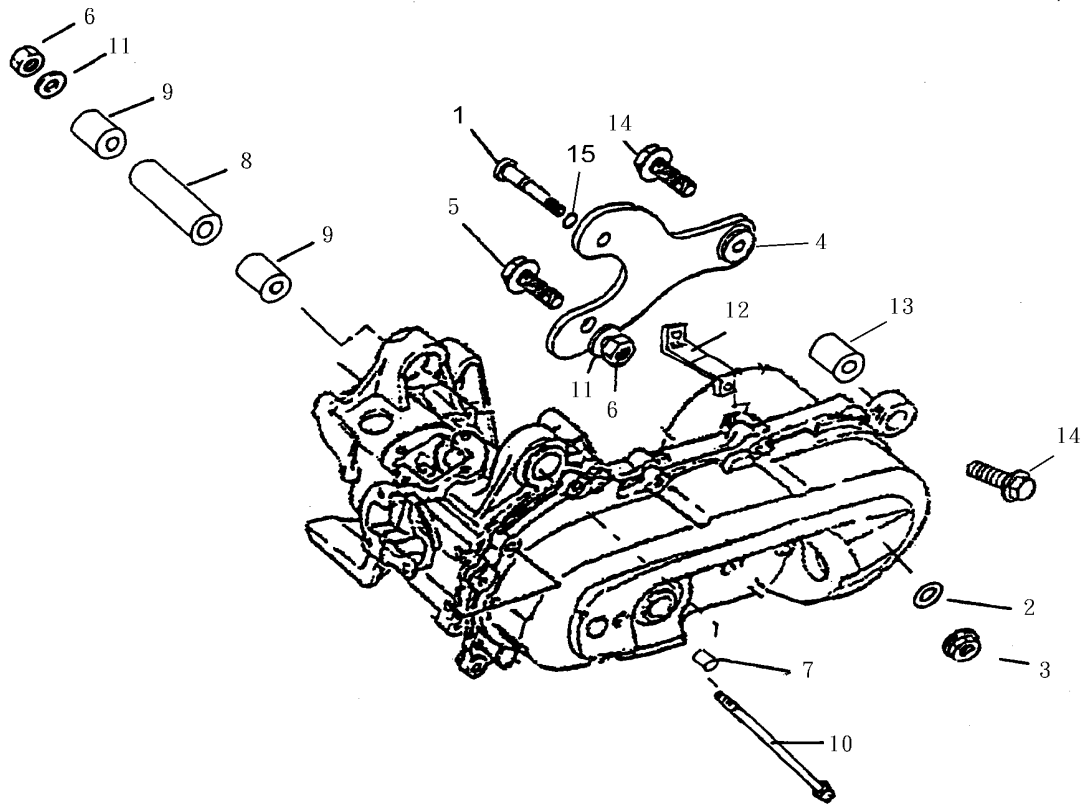

P/N	DESCRIPTION	PART NO.		Q"TY	REMARK
12-1	ENGINE BRACKET FIX SHAFT	45110-131-000		1	
12-2	PLAIN WASHER	94101-0816015-C		1	8×16×1.5
12-3	HEX PAN PHILLIPS BOLT WITH WASHER	94050-08000-C		1	M8
12-4	ENGINE BRACKET	50350-131-000		1	
12-5	HEX WASHER FACE BOLT	96000-12038-C		1	M12×38
12-6	NYLON INSERT LOCK NUT	90350-12000-C		2	M12
12-7	COLLAR	44311-111-000		1	
12-8	ENGINE FIXED TUBE (FRONT)	11150-131-000		1	L=103 mm
12-9	RUBBER BUSHING (FRONT)	96400-233538		2	
12-10	HEX WASHER FACE BOLT	96000-12222-14-C		1	M12×222
12-11	PLAIN WASHER	94101-1225020-C		2	12×25×2
12-12	OIL TANK FIX PLATE	55200-131-000		1	
12-13	RUBBER BUSHING	96400-082020		1	
12-14	HEX WASHER FACE BOLT	96000-08035-K		2	M8×35
12-15	O-RING	91307-111-000		1	

D-13 FRAME BODY (50cc)

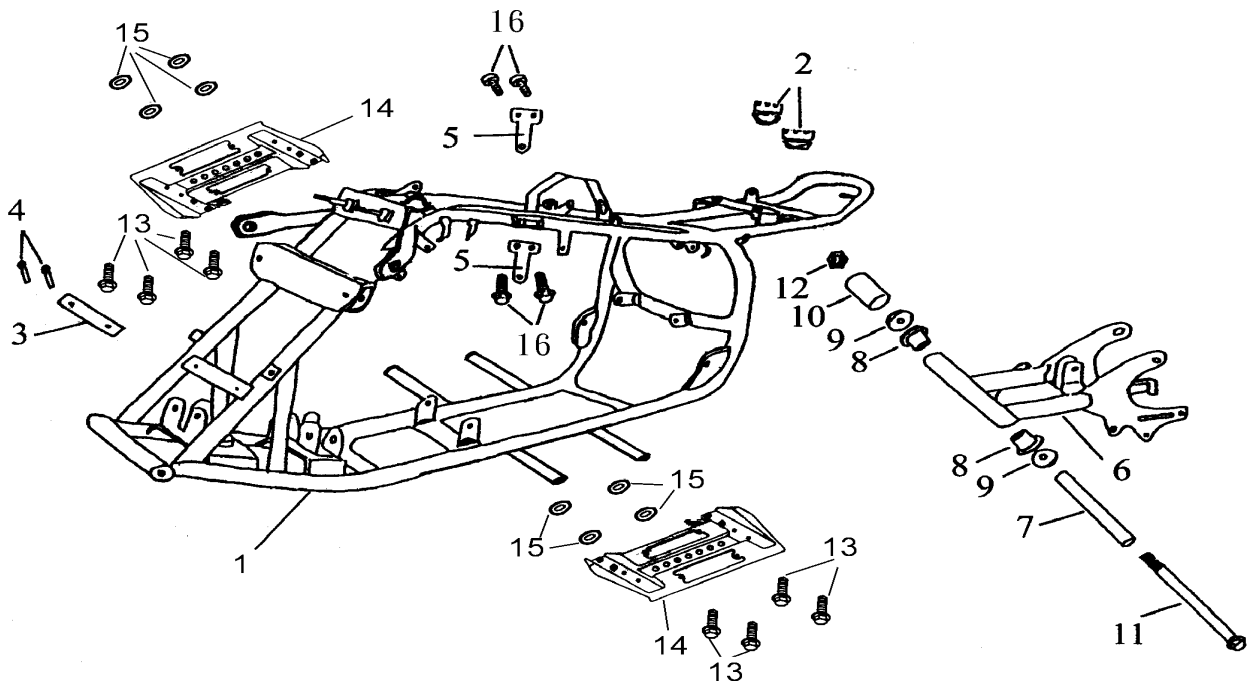

P/N	DESCRIPTION	PART NO.	Q'TY	REMARK
13-1	FRAME COMP	50100-132-001	1	
13-2	SEAT RUBBER	77220-131-000	2	φ37×φ13×23
13-3	FLANGE NUMBER PLATE	50130-131-000	1	
13-4	RIVET	90662-131-000	2	φ3×8
13-5	ENGINE BRACKET PLATE	50351-151-000	2	
13-6	SWING ARM SUB ASSY.	52410-131-000	1	
13-7	SWING ARM SPACER TUBE	52420-131-000	1	φ20×φ14.1×253.3
13-8	GREASE CONTAIN SEAT	52421-131-000	2	φ20
13-9	SWING ARM SEAL COVER	52422-131-000	2	
13-10	RUBBER SLEEVE	52423-131-000	1	
13-11	HEX WASHER FACE BOLT	96000-14290-C	1	M14×290
13-12	INSERT LOCK NUT	90350-14000-U-C	1	M14
13-13	HEX WASHER FACE BOLT	96000-08012-K	8	M8×12
13-14	FOOTWELL DOTTOM BOARD	51105-151-000	2	
13-15	FOOTREST GROMMER	64320-151-000	8	
13-16	HEX WASHER FACE BOLT	96000-08016-K	4	M8×16

D-14 SWING ARM, FOOTREST, FEND BAR (50cc)

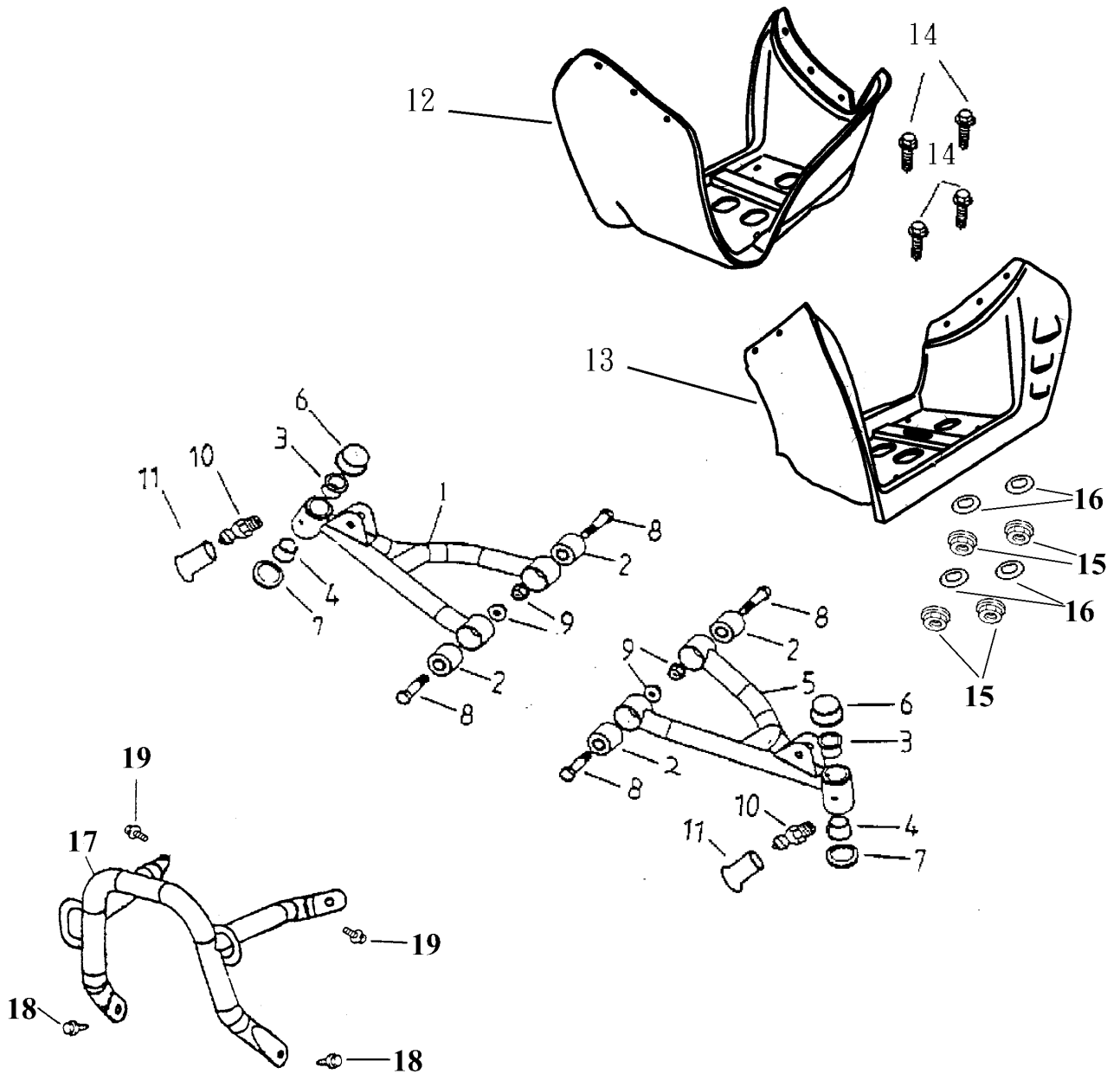

P/N	DESCRIPTION	PART NO.		Q'TY	REMARK
14-1	RIGHT SUSPENSION ARM	53030-131-000		1	
14-2	SUSPENSION ARM BUSH	96400-102827		4	φ10×φ28×27mm
14-3	GREASE CONTAIN SEAT	52522-131-000		2	φ15.5
14-4	GREASE CONTAIN SEAT	52523-131-000		2	φ17
14-5	LEFT SUSPENSION ARM	53130-131-000		1	
14-6	WATERPROOF COVER	51200-131-000		2	
14-7	DUSTPROOF RUBBER	52424-131-000		2	
14-8	HEX WASHER FACE BOLT	96000-10048-KL		4	M10×48
14-9	HEX FLANGE NUT	94050-10000-C		4	M 10
14-10	GREASE VALVE	51300-131-000		2	
14-11	GREASE VALVE RUBBER CAP	51301-131-000		2	
14-12	RH. FOOTREST ASSY.	64300-131-BLC0		1	
14-13	LH. FOOTREST ASSY.	64310-131-BLC0		1	
14-14	HEX WASHER FACE BOLT WITH PLAIN WASHER	92000-06016-K		8	M6×16
14-15	NYLON INSERT LOCK NUT	90350-06000-K		8	
14-16	PLAIN WASHER	94101-0613010-K		8	
14-17	FRONT FEND BAR ASSY.	50450-131-001		1	
14-18	HEX WASHER FACE BOLT	96000-08012-K		2	M8×12
14-19	HEX WASHER FACE BOLT	96000-06012-K		2	M6×12

D-15 FENDER (50cc)

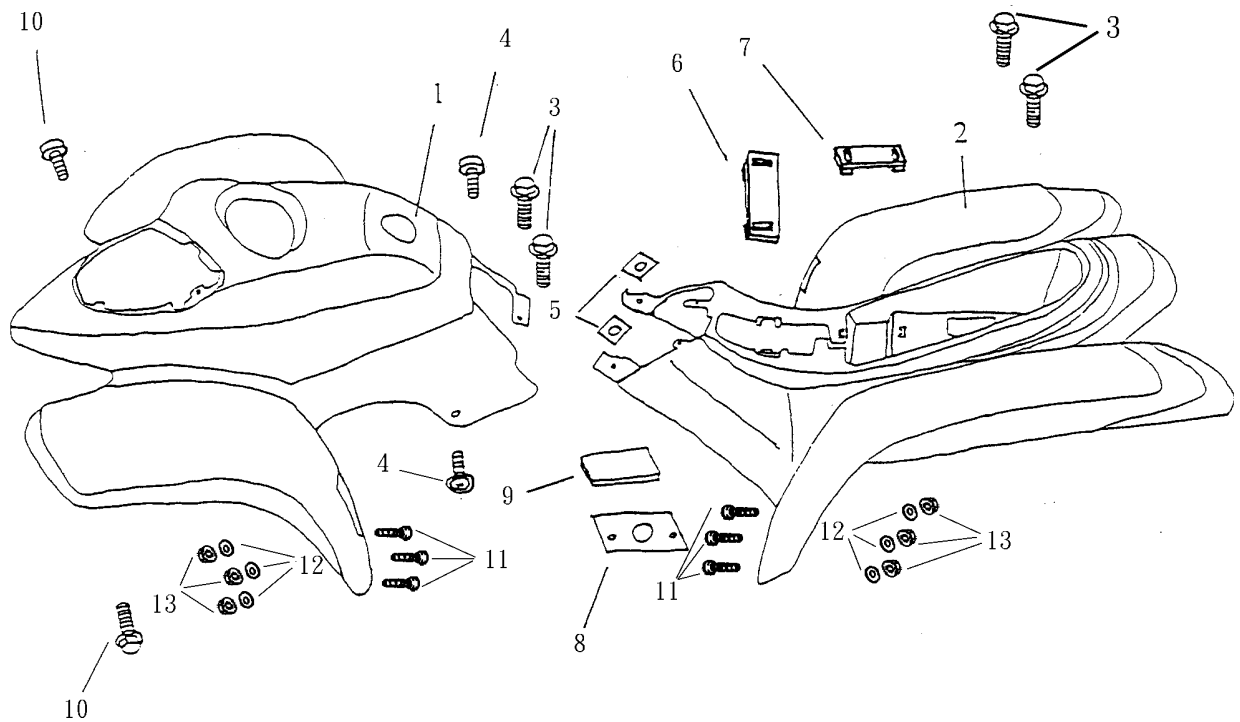

P/N	DESCRIPTION	PART NO.		Q'TY	REMARK
15-1	FRONT FENDER(WHITE)	61101-131-W038		1	
15-2	REAR FENDER(WHITE)	61001-131-W038		1	
15-3	HEX BOLT	92000-06016-K		4	M6×16
15-4	PAN PHILLIPS BOLT	96318-06016-K		2	M6×16
15-5	U PLATE NUT	90344-06000-C		2	M6
15-6	RUBBER BAND (BATTERY)	90750-131-000		1	
15-7	RUBBER BAND (TOOL BOX)	90760-131-000		1	
15-8	PROTECTOR PAD	80140-131-000		1	
15-9	BATTERY RUBBER	31510-131-000		1	
15-10	HEX BOLT WITH FIX WASHER	92003-06016-K		2	
15-11	PAN PHILLIPS BOLT	93100-05012-K		12	M5 ×12
15-12	PLAIN WASHER	94101-0514010-K		12	φ5×φ14×1mm
15-13	NYLON INSERT LOCK NUT	90350-05000-K		12	M5

D-16 SEAT (50cc)

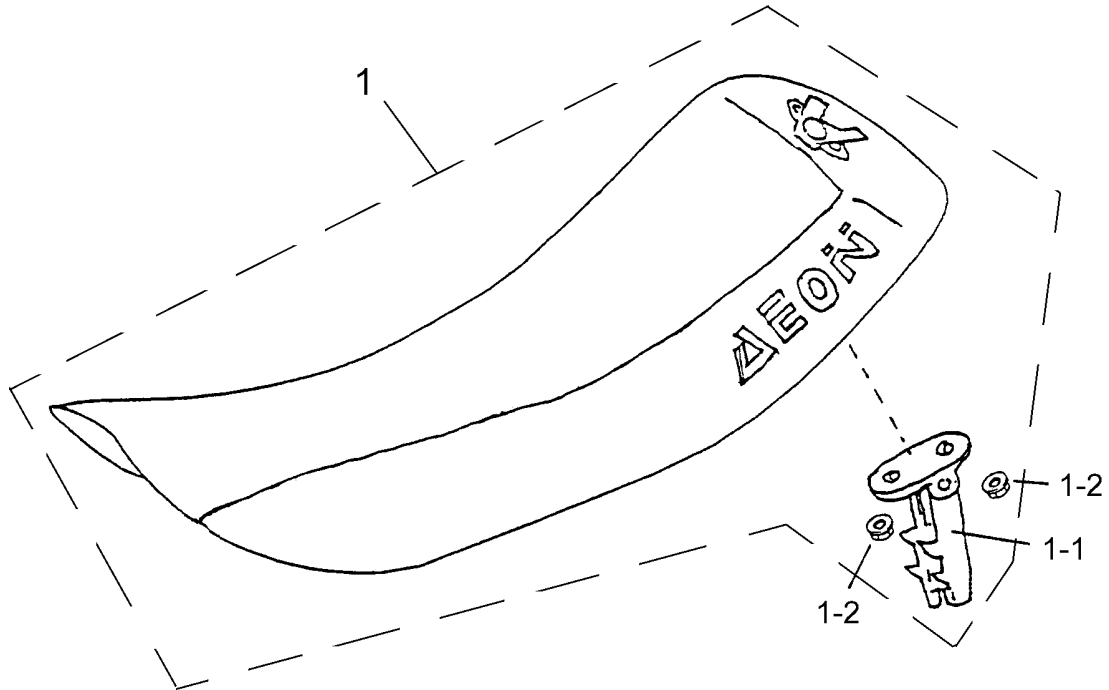

P/N	DESCRIPTION	PART NO.		Q'TY	REMARK
16-1	SEAT ASSY.	77200-131-000		1	AEON
16-1-1	SEAT FIX HOOK	77210-131-000		1	
16-1-2	HEX FLANGE NUT WITH SERRATION	94050-06000-C		2	M6

D-17 OIL TANK, FUEL TANK (50cc)

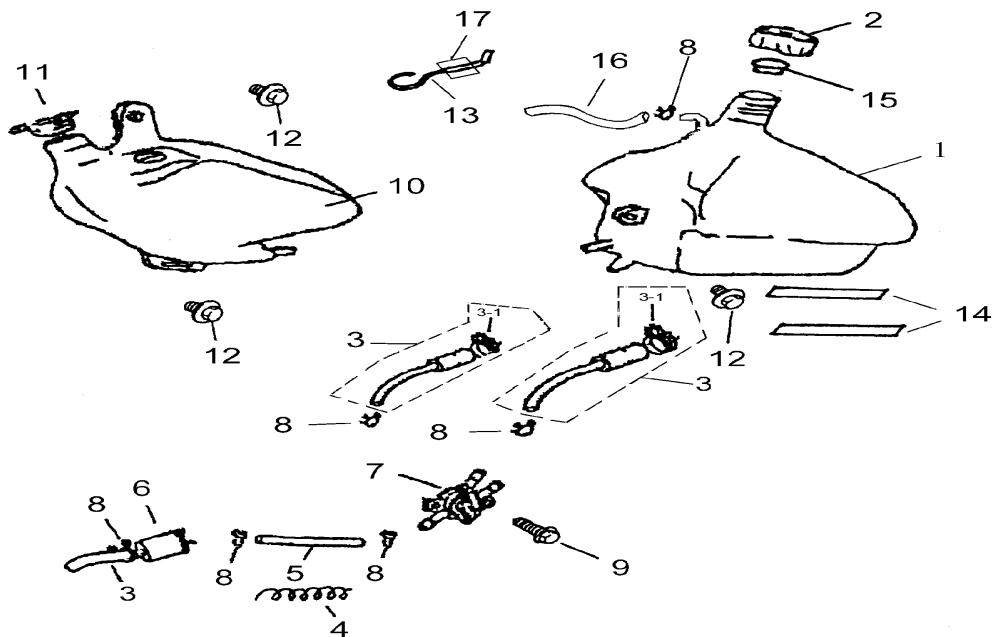

P/N	DESCRIPTION	PART NO.	Q'TY	REMARK
17-1	FUEL TANK COMP.	17500-151-000	1	
17-2	FUEL TANK CAP	17620-151-000	1	
17-3	FUEL TUBE	94401-05009	2	L=340
17-3-1	CLIP	94510-12000	2	12×0.8
17-4	PROTECTIVE SPRING	15311-113-000	1	
17-5	FUEL TUBE	94400-05009	1	L=150
17-6	FUEL FILTER ASSY.	16952-111-000	1	
17-7	MANUAL FUEL CUP ASSY.	16950-131-000	1	
17-8	CLIP	94510-08000	6	8×0.8
17-9	HEX WASHER FACE BOLT	96000-06012-K	1	M6×12
17-10	OIL TANK ASSY.	55100-131-000	1	
17-11	OIL TANK CAP	55105-111-000	1	
17-12	HEX BOLT	92000-06016-K	3	M6×16
17-13	FUEL TANK FIX HOOK	17640-131-000	1	
17-14	FUEL TANK RUBBER MAT	64319-131-000	2	
17-15	BREATHER FILM	17625-131-001	1	
17-16	BREATHER HOSE	94400-05009	1	L=200
17-17	SIDE OIL TUBE	94400-03565	1	L=35mm

D-18 SUSPENSION (50cc)

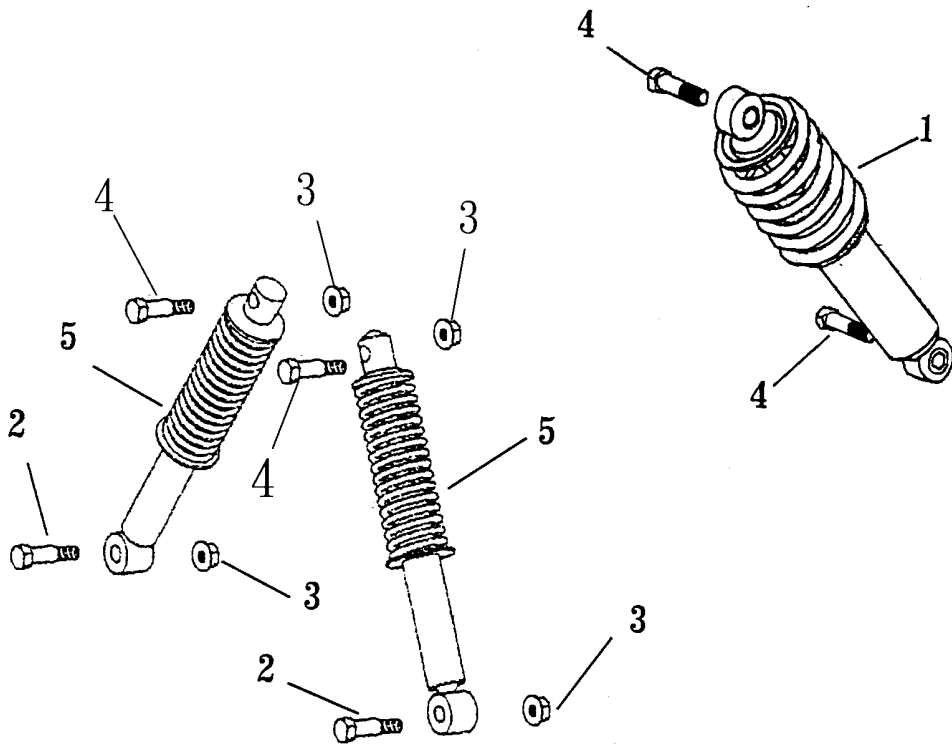

P/N	DESCRIPTION	PART NO.		Q'TY	REMARK
18-1	REAR SUSPENSION	52400-131-000		1	
18-2	HEX BOLT	92000-10040-KL		2	M10×40
18-3	NYLON INSERT LOCK NUT	94050-10000-C		4	M10
18-4	HEX WASHER FACE BOLT	96000-10040-KL		4	M10×40
18-5	FRONT SUSPENSION	51100-131-000		2	••

D-19 FRONT WHEEL (50 cc)

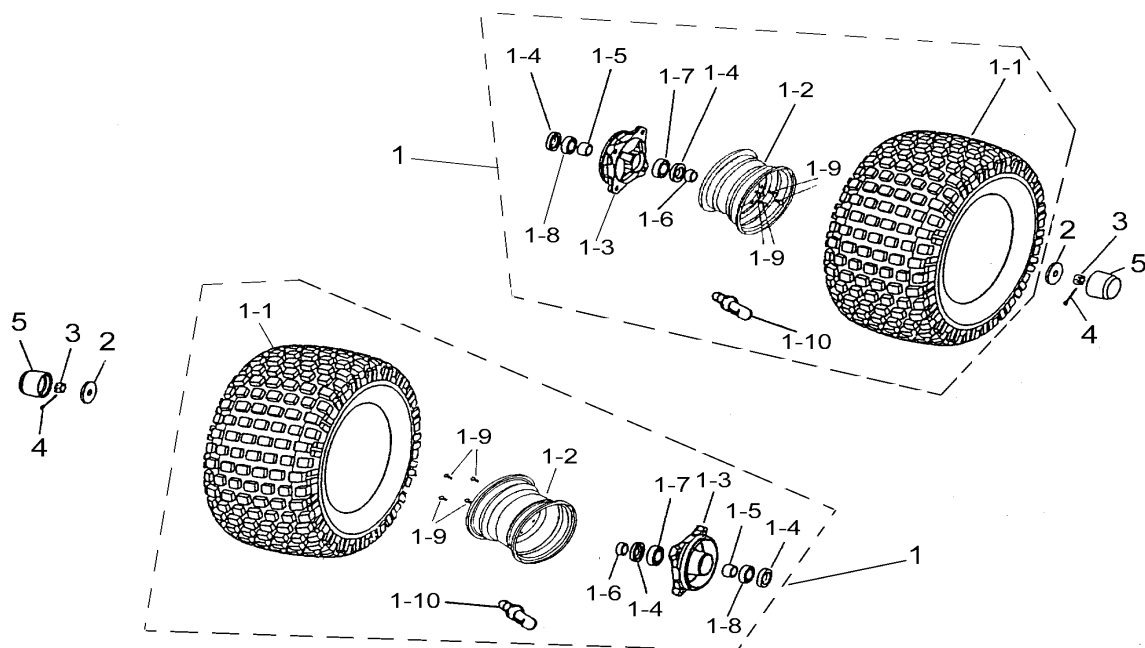

P/N	DESCRIPTION	PART NO.	Q'TY	REMARK
19-1	FRONT WHEEL ASS'Y	42700-131-00J1	2	16*8-7;HF-240A
19-1-1	WHEEL TIRE	42711-131-000	2	16x8-7;HF-240A
19-1-2	WHEEL RIM	42701-131-001	2	
19-1-3	FRONT BRAKE DRUM	45130-131-000	2	
19-1-4	OIL SEAL	96500-22357	4	φ22×φ35×7
19-1-5	INNER SPACER	44311-131-000	2	φ15×φ21.7×15
19-1-6	OUTER SPACER	44312-131-000	2	φ15×φ21.7×10
19-1-7	BEARING	96100-6002Z	2	6002Z
19-1-8	BEARING	96100-6003Z	2	6003Z
19-1-9	HEX WASHER FACE BOLT	96000-10020	8	M10×20
19-1-10	RIM VALVE	42616-131-000	2	
19-2	PLAIN WASHER	94101-1240050-C	2	12×40×5.0
19-3	INSERT LOCK NUT	90351-12000-C	2	M12
19-4	COTTER PIN	94201-32320	2	3.2×32
19-5	RUBBER CAP	42730-151-000	2	

D-20 REAR WHEEL (50 cc)

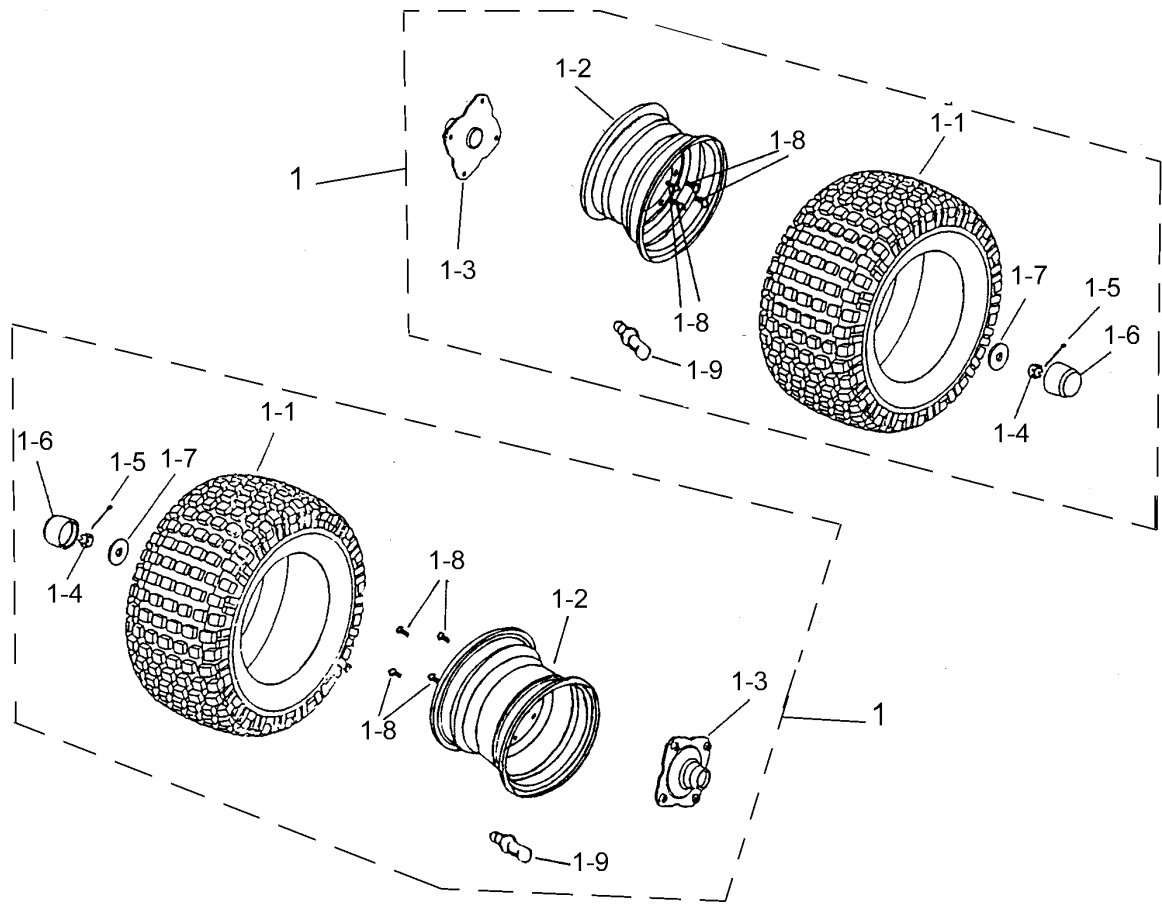

P/N	DESCRIPTION	PART NO.	Q'TY	REMARK
20-1	REAR WHEEL ASS'Y	42800-131-00JA1	2	16*8-7;HF-240A
20-1-1	WHEEL TIRE	42711-131-000	2	16x8-7;HF-240A
20-1-2	WHEEL RIM	42701-131-001	2	
20-1-3	SHAFT OONNECTER	97010-131-00A	2	
20-1-4	INSERT LOCK NUT	90351-14000-C	2	M14
20-1-5	COTTER PIN	94201-32320	2	3.2x32
20-1-6	RUBBER CAP	42730-151-000	2	
20-1-7	PLAIN WASHER	94101-1440045-C	2	14x40x4.5
20-1-8	HEX WASHER FACE BOLT	96000-10020	8	M10x20
20-1-9	RIM VALVE	42616-131-000	2	

D-22 REAR BRAKE (50cc)

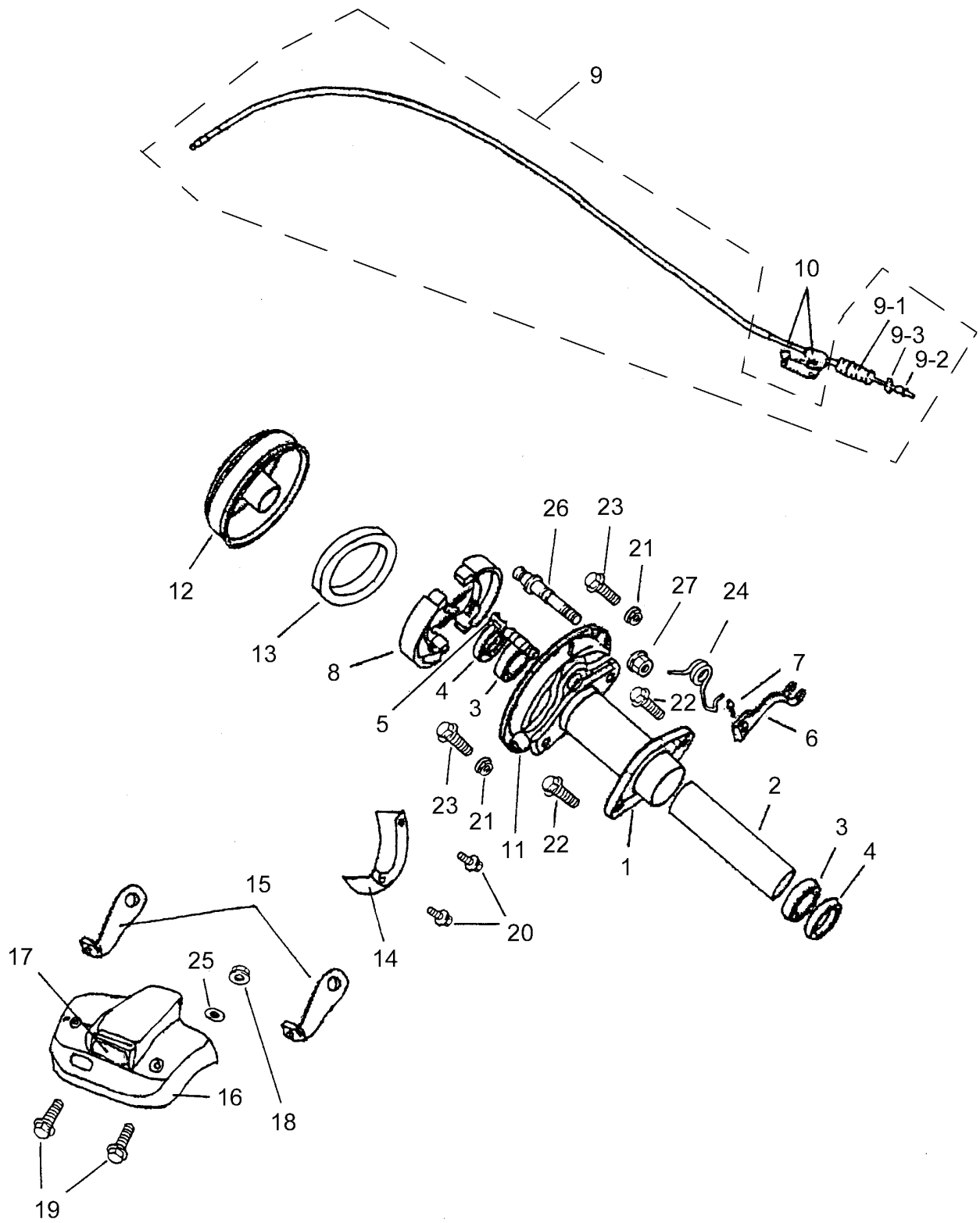

P/N	DESCRIPTION	PART NO.		Q'TY	REMARK
22-1	REAR AXLE FIX SEAT	42805-131-000		1	
22-2	SPACER TUBE	42810-131-000		1	
22-3	BEARING	96100-6006ZZ		2	6006ZZ
22-4	OIL SEAL	96500-355511		2	φ35×φ55×11
22-5	REAR BRAKE CAM SHAFT	43141-131-000		1	
22-6	REAR BRAKE ARM	43410-131-000		1	
22-7	HEX WASHER FACE BOLT	96000-06032-10-C		1	M6×32
22-8	REAR BRAKE SHOE COMP.	43120-119-00A		1	φ130
22-9	REAR BRAKE CABLE	43450-131-000		1	
22-9-1	REAR BRAKE CABLE SPRING	15312-119-000		1	
22-9-2	BRAKE ADJUST NUT	95015-41000		1	
22-9-3	REAR BRAKE FIXTUBE	95015-31001		1	
22-10	HEX WASHER FACE BOLT	94050-08000-C		2	M8
22-11	REAR BRAKE PLATE	43510-131-000		1	
22-12	REAR BRAKE DRUM	43520-131-000		1	
22-13	PROTECTIVE RUBBER	43521-131-000		1	
22-14	PROTECTIVE COVER	40521-131-001		1	
22-15	REAR COVER FIX PLATE	40551-131-000		2	
22-16	REAR COVER	40550-151-000		1	
22-17	REAR REFLECTOR	33741-131-00A		1	
22-18	HEX FLANGE NUT WITH SERRATION	94050-05000-C		1	M5
22-19	HEX WASHER FACE BOLT	90110-06014-18-K		2	M6×12
22-20	HEX WASHER FACE BOLT	96000-08012-K		3	M8×12
22-21	HEX FLANGE NUT WITH SERRATION	94050-12000-C		2	M12
22-22	HEX WASHER FACE BOLT	96000-12028-C		2	M12×28
22-23	HEX BOLT	43530-131-000-C		2	M12×50
22-24	REAR BRAKE ARM SPRING	43420-131-000		1	
22-25	PLAIN WASHER	94101-0519010-C		1	5×19×1.0
22-26	REAR BRAKE FIX SHAFT	45110-119-001		1	
22-27	NYLON INSERT LOCK NUT	90350-08000-C		1	M8

D-23 HANDLE BAR (50cc)

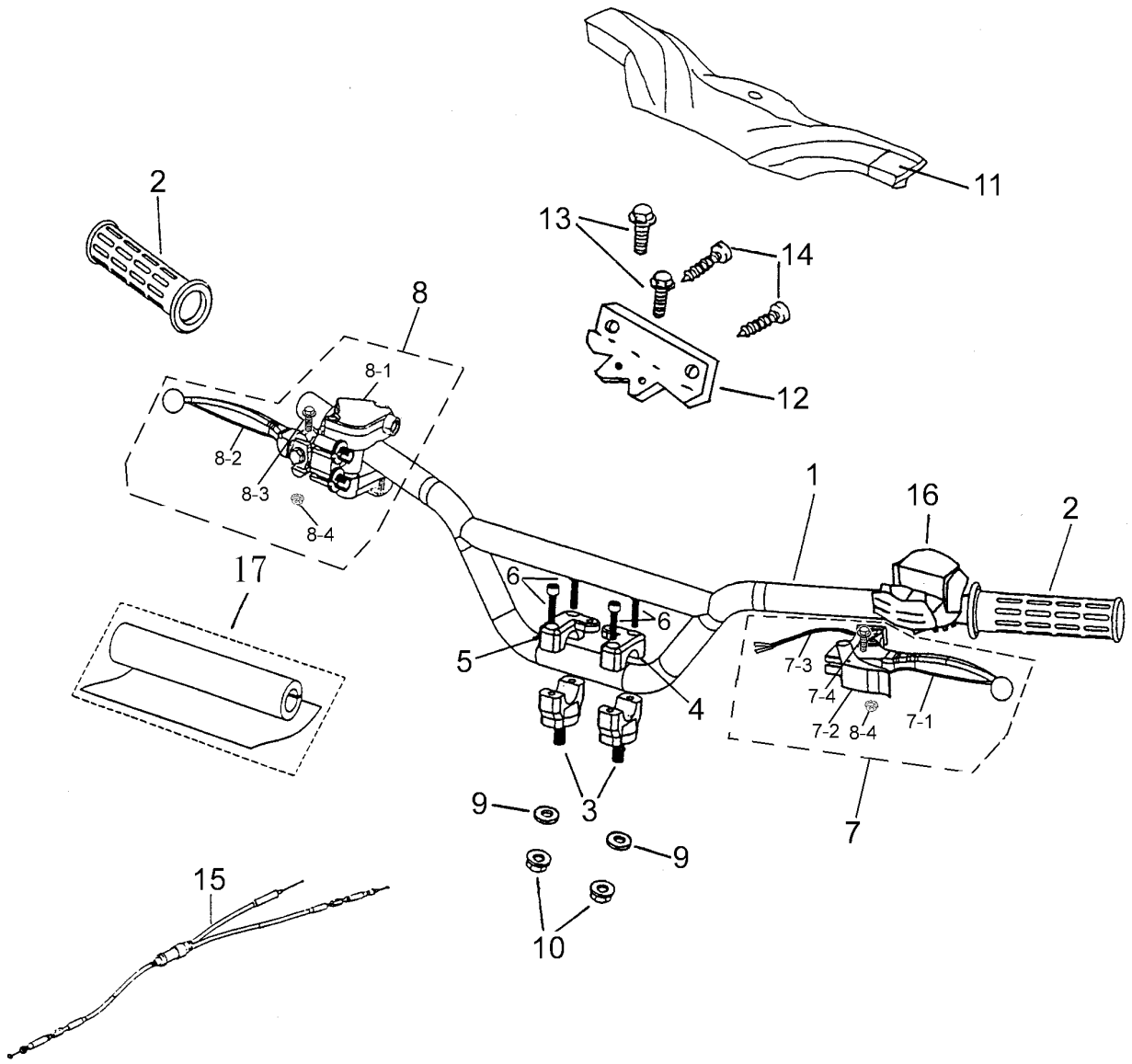

P/N	DESCRIPTION	PART NO.		Q'TY	REMARK
23-1	HANDLE BAR COMP.	53100-131-000		1	
23-2	HANDLE GRIP	53165-131-000		2	
23-3	HANDLE BAR CLAMP SADDLE	53200-131-000		2	
23-4	HANDLE BAR CLAMP COVER (L)	53210-131-000		1	
23-5	HANDLE BAR CLAMP COVER (R)	53220-131-000		1	
23-6	HEX SOCKET SCREW	91000-06025-K		4	M6x25
23-7	LEFT LEVEL ASSY	53171-131-001		1	
23-7-1	L. SIDE LEVEL	53178-131-000		1	
23-7-2	HAND BRAKE PIECE	53179-131-000		1	
23-7-3	BRAKE SENSOR SWITCH CABLE	53173-131-000		1	
23-7-4	L.LEVER SET BOLT	90116-131-000		1	M6x23
23-8	RIGHT LEVEL ASSY	53172-131-001		1	
23-8-1	R. SIDE LEVEL SEAT	53176-131-000		1	
23-8-2	R. SIDE LEVEL	53175-131-000		1	
23-8-3	RIGHT LEVER SET BOLT	90115-131-000		1	M6x23
23-8-4	NYLON INSERT LOCK NUT	90350-06000-K		2	M6
23-9	PLAIN WASHER	94101-1022020-C		2	10x22x2
23-10	NYLON INSERT LOCK NUT	90350-10000-C		2	M10
23-11	HANDLE BAR PROTECT COVER	53300-131-W038		1	
23-12	PROTECT COVER FIX PLATE	53310-131-000		1	
23-13	HEX WASHER FACE BOLT	96000-06012-K		2	M6x12
23-14	TAPPING SCREW	93903-05012-K		2	M5x12
23-15	THROTTLE CABLE	17910-131-000		1	
23-16	L. SWITCH ASS'Y	35151-131-001		1	
23-17	HANDLE BAR PROTECT RUBBER	53320-131-000		1	

D-24 REAR WHEEL AXLE (50cc)

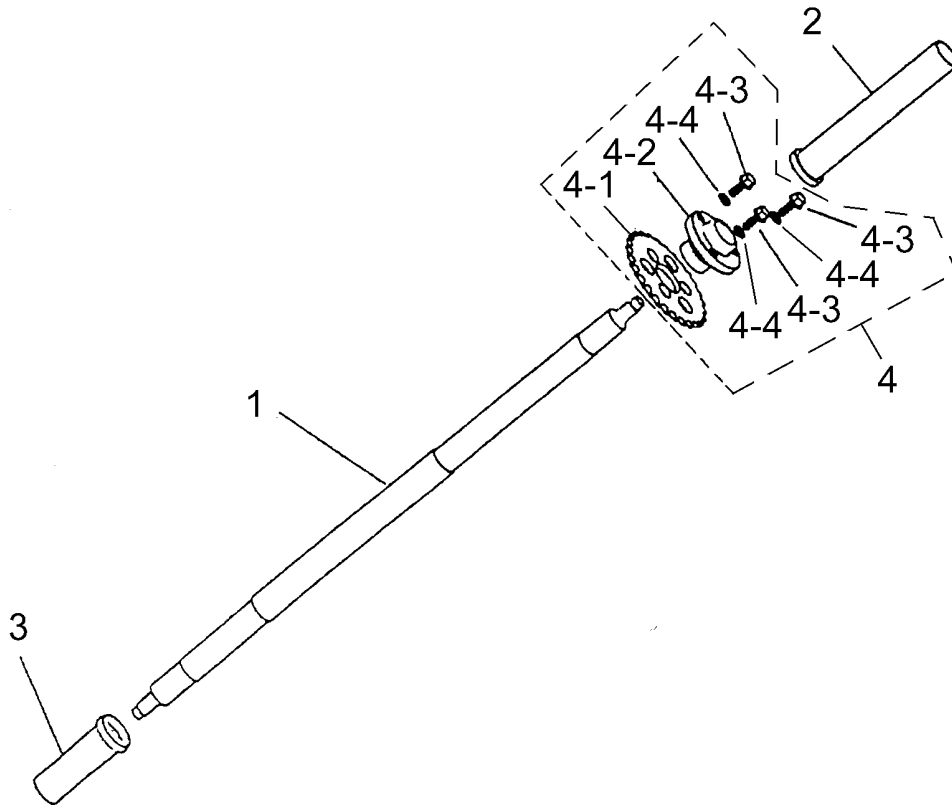

P/N	DESCRIPTION	PART NO.		Q'TY	REMARK
24-1	REAR AXLE	97000-131-001		1	
24-2	SPACER TUBE (R)	97100-131-000		1	
24-3	SPACER TUBE (L)	97110-131-000		1	
24-4-1	FINAL DRIVE SPROCKET	41201-131-000		1	28T
24-4-2	FINAL DRIVE SPROCKET HOLDER	41210-131-000		1	
24-4-3	HEX WASHER FACE BOLT	96000-08020-K		3	M8×20
24-4-4	SPRING WASHER	94111S-08000		3	φ8
24-4	RINAL DRIVE SPROCKET ASS'Y	41200-131-000		1	

D-25 CHAIN (50cc)

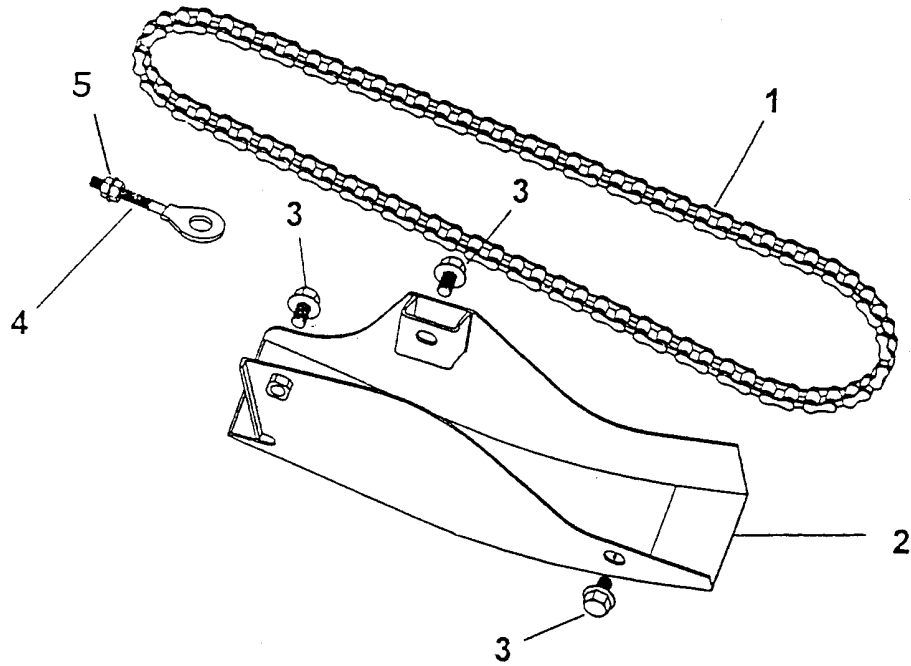

P/N	DESCRIPTION	PART NO.		Q'TY	REMARK
25-1	DRIVE CHAIN ASSY.	40530-131-000		1	#428H,78
25-2	PROTECT COVER	40520-131-000		1	
25-3	HEX WASHER FACE BOLT	96000-08012-K		3	M8×12
25-4	ADJUSTER,CHAIN	40543-131-000		1	
25-5	HEX NUT	94001-06000-C		2	M6

D-26 STEERING (50cc)

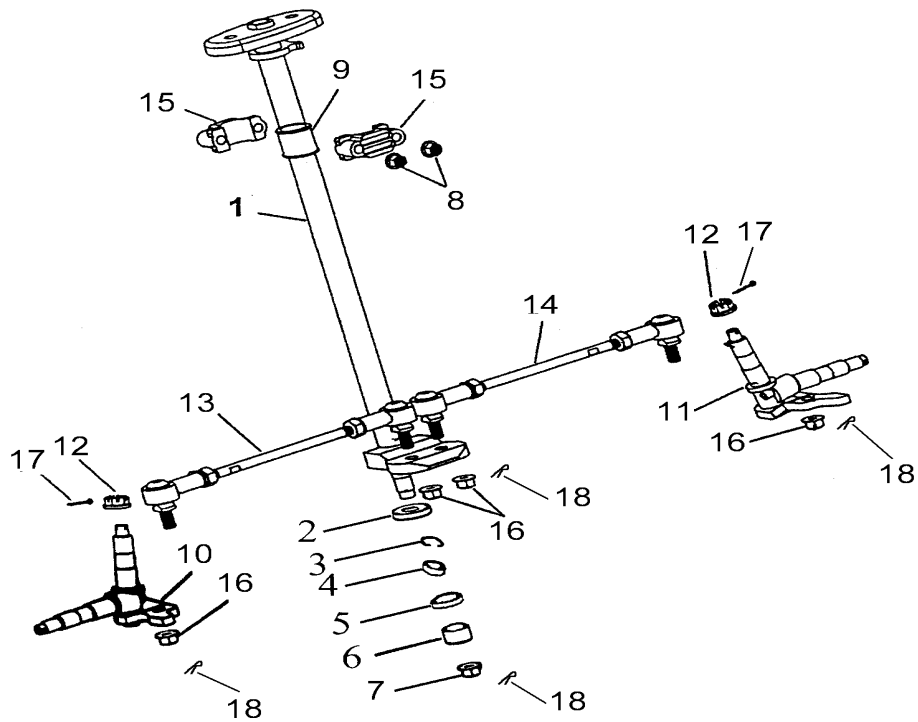

P/N	DESCRIPTION	PART NO.	Q'TY	REMARK
26-1	STEERING SHAFT	51107-131-001	1	
26-2	OIL SEAL	96500-18327	1	φ18×φ32×7
26-3	CIRCLIP	94512-3200R	1	R-32
26-4	RADIAL BALL BEARING	96100-6002ZZ	1	6002ZZ
26-5	OIL SEAL	96500-22357	1	φ22×φ35×7
26-6	SPACER TUBE	44311-131-000	1	φ15×φ21.7×15
26-7	NYLON INSERT LOCK NUT	90350-14000-UC	1	M14
26-8	NYLON INSERT LOCK NUT	94050-08000-C	2	M8
26-9	STEERING SHAFT PU SLEEVE	51220-131-000	1	
26-10	KNUCKLE (L)	51310-131-000	1	
26-11	KNUCKLE (R)	51320-131-000	1	
26-12	INSERT LOCK NUT	90352-10000-C	2	M10
26-13	STEERING TIE-ROD ASSY (L)	53410-131-002	1	
26-14	STEERING TIE-ROD ASSY (R)	53420-131-002	1	
26-15	STEERING SHAFT HOLD	53500-131-000	2	
26-16	NYLON INSERT LOCK NUT	90350-10000-UC	4	M10
26-17	COTTER PIN	94201-16190	2	1.6×19
26-18	B COTTER PIN	94201-24190	5	

D-27 FRONT HEAD LIGHT, TAIL LIGHT (50cc)

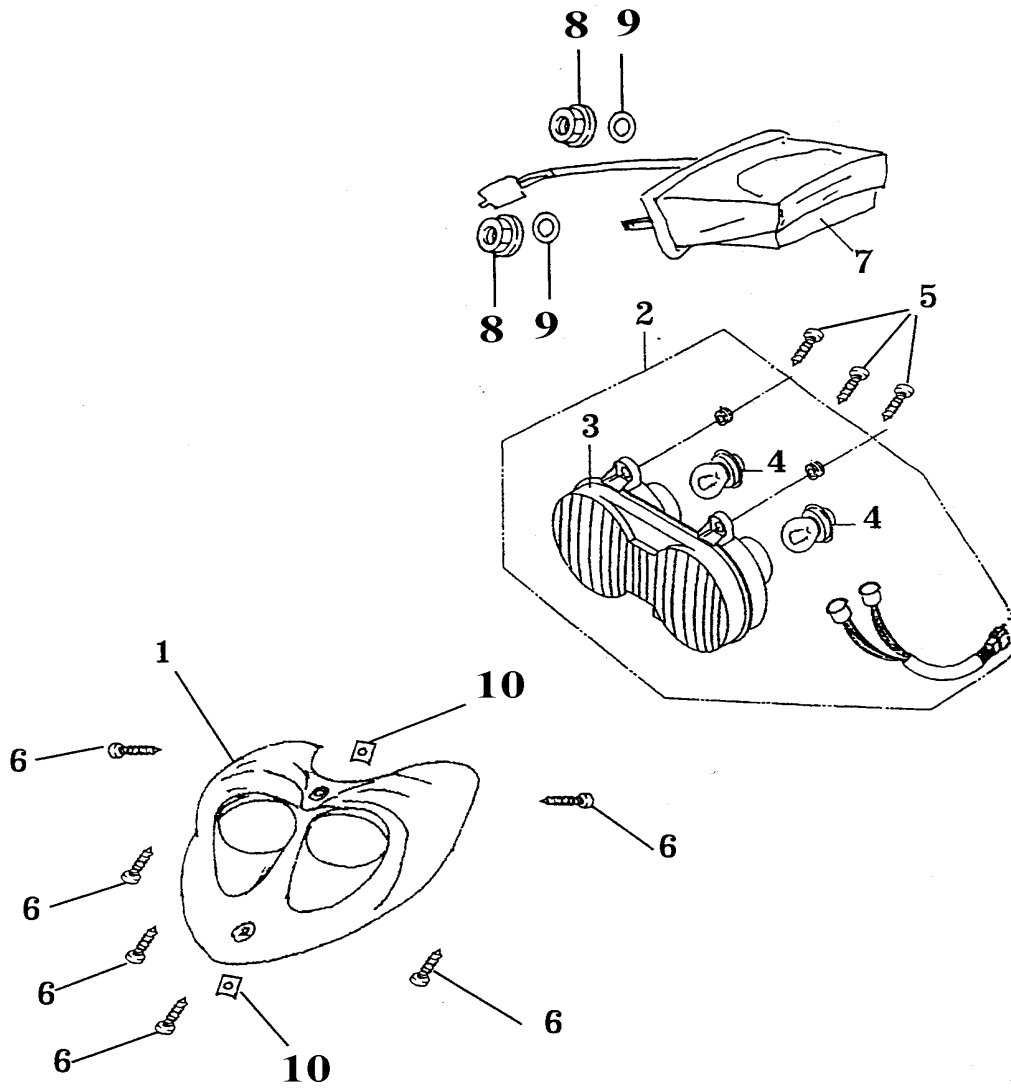

P/N	DESCRIPTION	PART NO.		Q'TY	REMARK
27-1	HEAD LIGHT COVER	64321-131-WB06		1	
27-2	HEAD LIGHT ASS'Y	33100-116-00B		1	
27-3	HEAD LIGHT LENS	33110-116-00A		1	
27-4	HEAD LIGHT BULB	34901-116-000		2	12V-18/18W
27-5	TAPPING SCREW	93903-05016-K		3	M5×16
27-6	TAPPING SCREW	93903-04016-K		6	M4×16
27-7	TAIL LIGHT ASS'Y	33700-131-000		1	
27-8	HEX FLANGE NUT WITH SERRATION	94050-06000-C		2	M6
27-9	PLAIN WASHER	94101-0619010-C		2	φ6×φ19×1
27-10	U PLATE NUT	90345-04000-2T		2	M4

D-28 GENERATOR, START MOTOR (50cc)

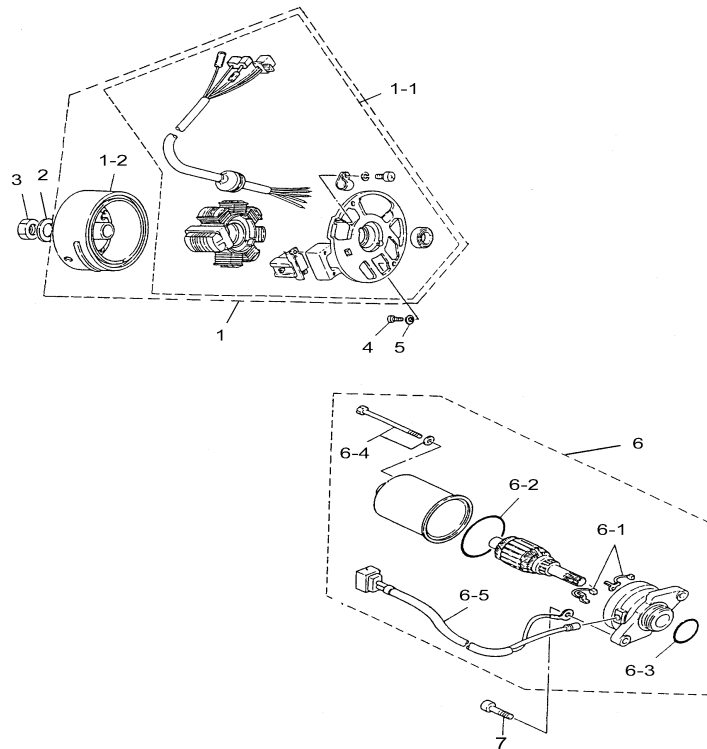

P/N	DESCRIPTION	PART NO.		Q'TY	REMARK
28-1	GENERATOR ASS'Y	31100-113-000		1	
28-1-1	STATOR COMP	31120-113-000		1	
28-1-2	GENERATOR FACE FLYWHEEL	31110-113-000		1	
28-2	PLAIN WASHER	94101-1022020-C		1	10×22×2
28-3	HEX FLANGE NUT WITH SERRATION	94050-10000-C		1	M10
28-4	HEX SOCKET BOLT	91000-06016-K		2	M6×16
28-5	PLAIN WASHER	94101-0613010-C		2	6×13×1
28-6	STARTING MOTOR ASS'Y	31200-113-000		1	
28-6-1	BRUSH SET	31201-113-000		1	
28-6-2	OIL RING	91342-113-000		1	
28-6-3	OIL RING	91323-113-000		1	
28-6-4	BOLT SET	90115-113-000		2	
28-6-5	CORD COMP	31202-113-000		1	
28-7	HEX SOCKET BOLT	91000-06020-C		2	M6×20

D-29 ELECTRICAL PARTS (50cc)

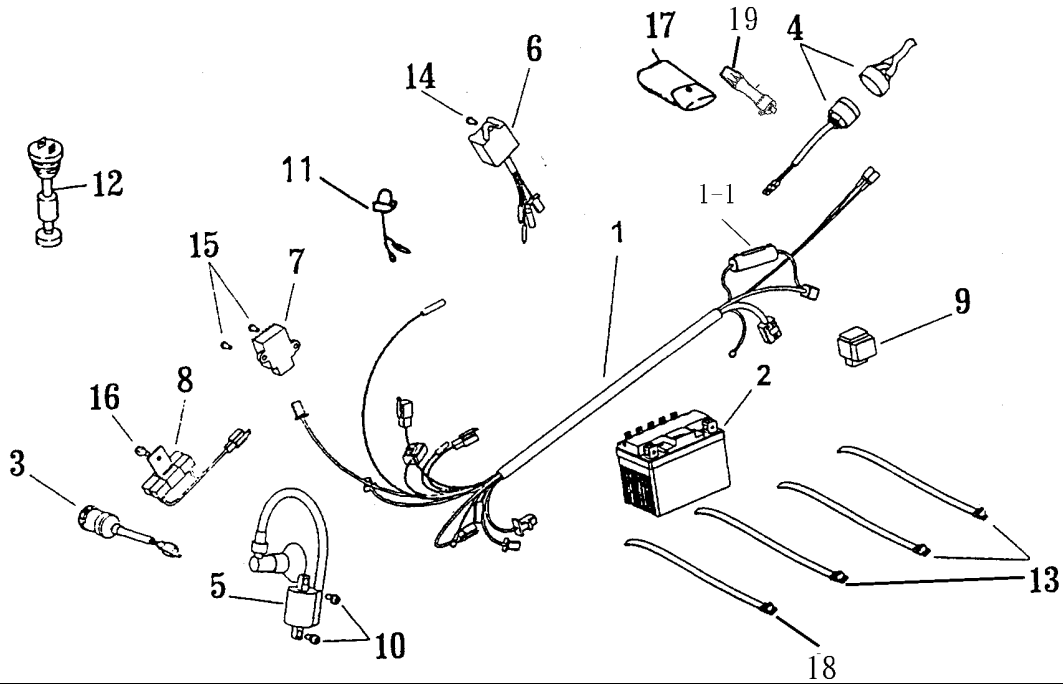

P/N	DESCRIPTION	PART NO.	Q'TY	REMARK
29-1	MAIN WIRE ASSY.	32100-131-00A	1	
29-1-1	FUSE	98200-113-000	1	
29-2	BATTERY	31500-111-000	1	
29-3	MAIN SWITCH ASSY.	35100-131-001	1	
29-4	SAFETY SWITCH	30701-131-000	1	
29-5	IGNITION COIL ASSY.	30510-151-000	1	
29-6	C.D.I. UNIT ASSY.	30410-117-000	1	
29-7	RECTIFIER®ULATOR	31600-113-000	1	
29-8	RESISTOR ASSY.	38601-111-000	1	
29-9	STARTER RELAY ASSY.	38501-111-000	1	
29-10	HEX WASHER FACE WASHER	96000-06022-K	2	M6×22
29-11	OIL QUAYITY WORN LAMP	34908-131-000	1	
29-12	OIL LEVEL GAUGE ASS'Y	35410-113-000	1	
29-13	STRAP	90569-131-000	3	ALT-200M-B
29-14	HEX WASHER FACE WASHER	96000-06016-K	1	M6×16
29-15	PAN PHILLIPS BOLT	93500-05014-C	2	M5×14
29-16	HEX WASHER FACE WASHER	96000-06012-K	1	M6×12
29-17	TOOL BAG	50120-111-000	1	
29-18	STRAP	90769-111-000	1	LR-220AH
29-19	TIRE PRESSURE GUIDE	42620-131-000	1	
29-20		94103-06000-C	1	

D-30 DECAL (50cc)

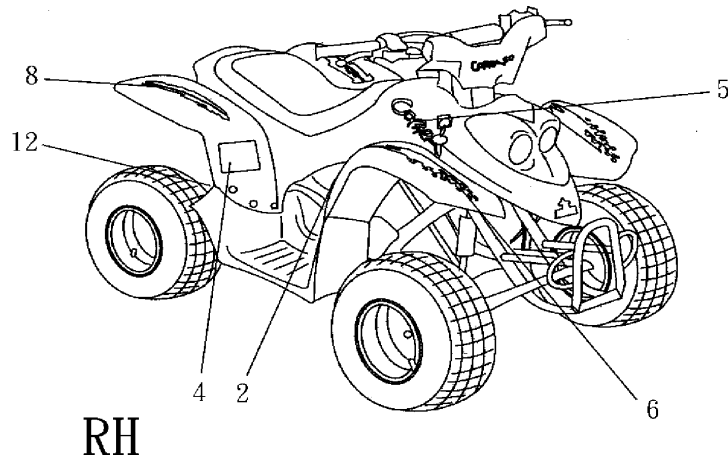
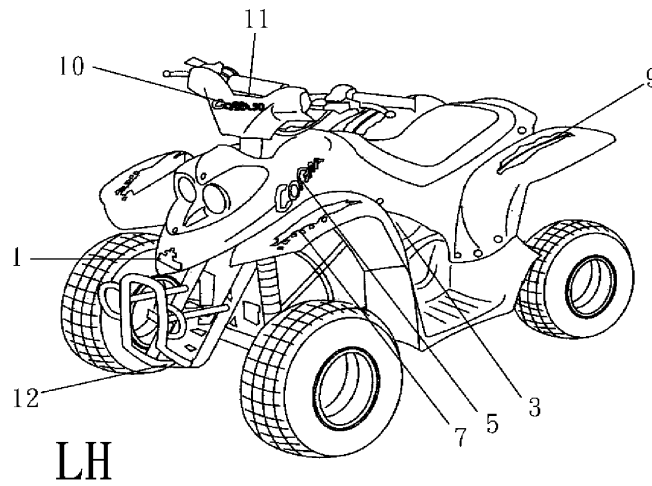

P/N	DESCRIPTION	PART NO.	Q'TY	REMARK
30-1	AEON STICKET	87711-131-000	1	
30-2	STICKER WARING(Y-6)	87751-131-00A	1	Y-6
30-3	STICKER WARING(TIRE PSI)	87752-131-000	1	
30-4	STICKER WARING (CONFINE)	87753-131-000	1	
30-5	FRONT FENDER STICKER.	87720-131-001	2	
30-6	FRONT FENDER STICKER S/R.	87722-131-000	1	
30-7	FRONT FENDER STICKER S/L.	87723-131-000	1	
30-8	REAR FENDER STICKER R.	87730-131-001	1	
30-9	FEAR FENDER STICKER L.	87731-131-001	1	
30-10	HANDLE COVER STICKER	87760-131-001	1	
30-11	OIL LAMP STICKER.	87761-131-000	1	
30-12	FRAME STICKER.	87762-131-000	2	

D-31 STANDARD ACCESSORY (50cc)



ASSEMBLY DRAW

WHEEL ASSEMBLY

1. Install the four wheels on the chassis.
2. Install the washer and nut on the shaft.
3. Tighten the nut. Torque:
Front wheel: 49-52 ft.lbs.
(6.8-7.1 kg-m)
Rear wheel: 65-67 ft.lbs.
(9.0-9.2 kg-m)
4. Insert the cotter pin, and bend around shaft.
5. Inflate front and rear tires to 3 psi.
6. Install the rubber cap.

HANDLE BAR ASSEMBLY

1. Assemble Handlebar clamp (shown as NO.1,2 with NO.3,4)
Torque: 7.2 ft.lbs (1.0 kg-m).
2. Lock fix plate NO.5 onto NO.1,2.
Torque: 7.2 ft.lbs (1.0 kg-m).
3. Connect the oil warning cable and light cable (connect with same specified color).
4. Assemble the handlebar pad.

FOOTREST ASSEMBLY

1. Assemble footrest and fasten the M6x16mm bolts with 6mm nuts.
Torque: 7.2 ft.lbs (1.0 kg-m).
2. Using 5mm bolts, washer, nuts provided, install the RH and LH footrest.
Torque the bolts to 3.5 ft.lbs (0.5 kg-m).

ASS-131-B

P/N	DESCRIPTION	PART NO.	Q'TY	REMARK
31-1	OWNERS MANUAL	OWNER-131-A	1	
31-2	ASSEMBLY DRAW	ASS-131B	1	

NO.1

14-12		64310-131-000	1				
14-18		83574-131-000	4		64305-131-000	1	
22-3		96100-6006ZZ	2				
22-4		96500-35511	2				
22-2		42810-131-000	1				
22-1		42805-131-000	1				
22-26		45110-119-001	1		42803-131-000	1	
22-23		43530-131-000	2				
22-27		90350-08000-C	1				
22-11		43510-131-000	1				
14-1		53030-131-000	1				
14-2		96400-102827	2				
14-3		52522-131-000	1				
14-4		52523-131-000	1				
14-6		51200-131-000	1		53025-131-000	1	
14-7		52424-131-000	1				
14-10		51300-131-000	1				
14-11		51301-131-000	1				
14-5		53130-131-000	1				
14-2		96400-102827	2				
14-3		52522-131-000	1				
14-4		52523-131-000	1				
14-6		51200-131-000	1		53125-131-000	1	
14-7		52424-131-000	1				
14-10		51300-131-000	1				
14-11		51301-131-000	1				
21-3		45020-131-000	1				
21-4		45420-131-000	1				
21-5		45140-131-000	1				
21-6		45120-131-00A	1		45018-131-000	1	
21-7		45143-131-000	1				
21-8		96000-05024-C	1				

NO.2

21-1		45010-131-000	1				
21-2		45410-131-000	1				
21-5		45141-131-000	1		45008-131-000	1	
21-6		45120-131-00A	1				
21-7		45143-131-000	1				
21-8		96000-05024-C	1				
13-12		52410-131-000	1				
13-13		52420-131-000	1		52405-131-000	1	
13-14		52421-131-000	1				
13-15		52422-131-000	1				
13-16		52423-131-000	1				
14-16		50465-131-001	1		50455-131-000	1	
14-17		50450-131-BLC0	1				
14-19		96000-06012-K	4				
14-20		50466-131-000	2				
17-3		94401-05009	2		16900-131-000	1	
17-5		94400-05009	1				
17-6		16952-111-000	1				
17-7		16950-131-000	1				
17-8		94510-08000	5				
22-1		42805-131-000	1		42804-131-000	1	
22-2		42810-131-000	1				
22-3		96100-6006Z	2				
22-4		96500-35511	2				
22-11		43510-131-000	1				
22-23		43530-131-000	2				
22-26		45110-119-001	1				
22-27		90350-08000-C	1				