

Tomos TX50

Reservdelslista



J.O.FORSBERG
RESERVDLAR AB

BOX 283 573 23 TRANÅS
0140-38 50 30 TELEFAX 0140-155 03

CRANKCASE, CYLINDER, PISTON

A

230 156 - engine
227 331 - gasket set

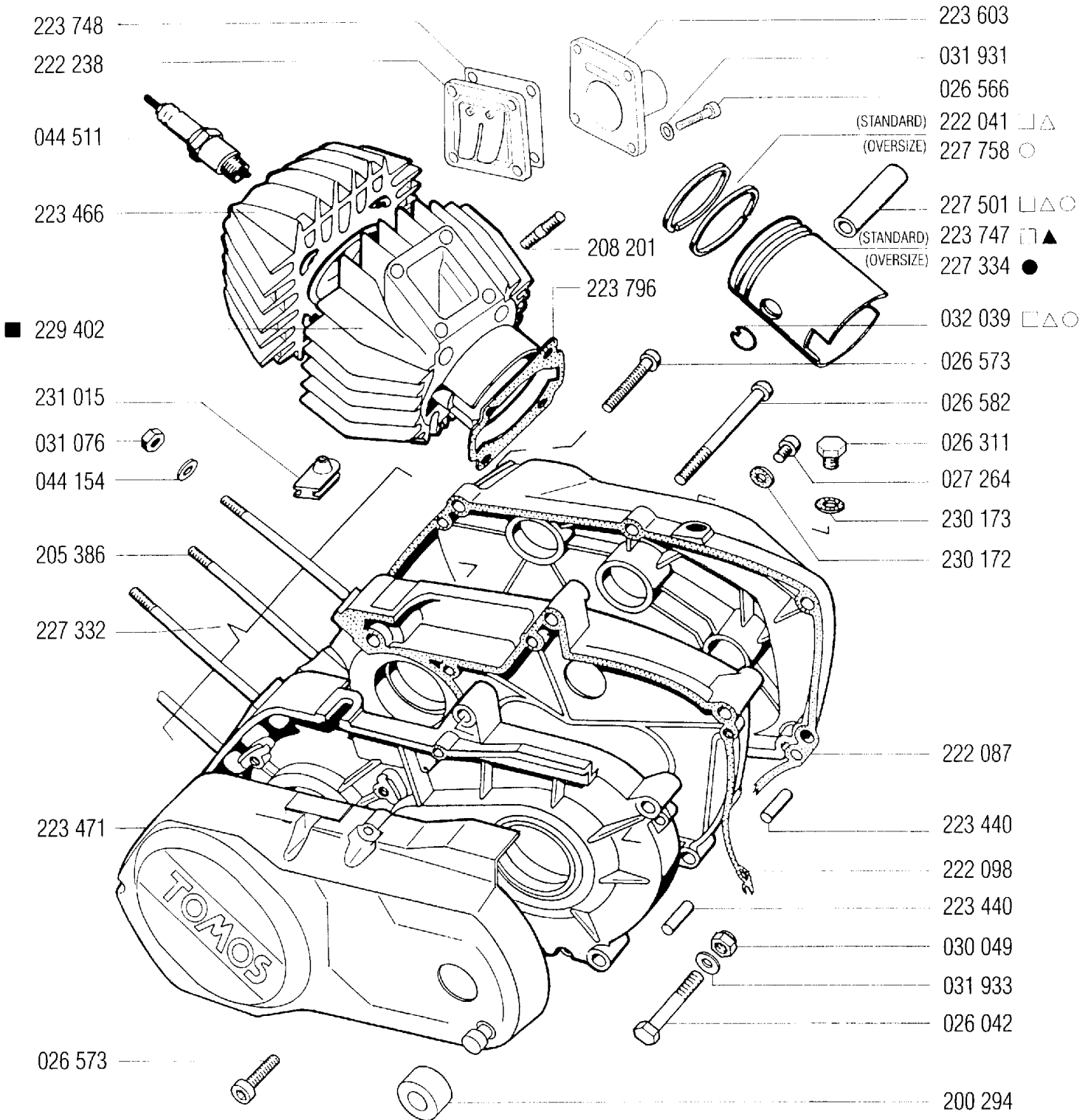

CRANKSHAFT, CLUTCH

B

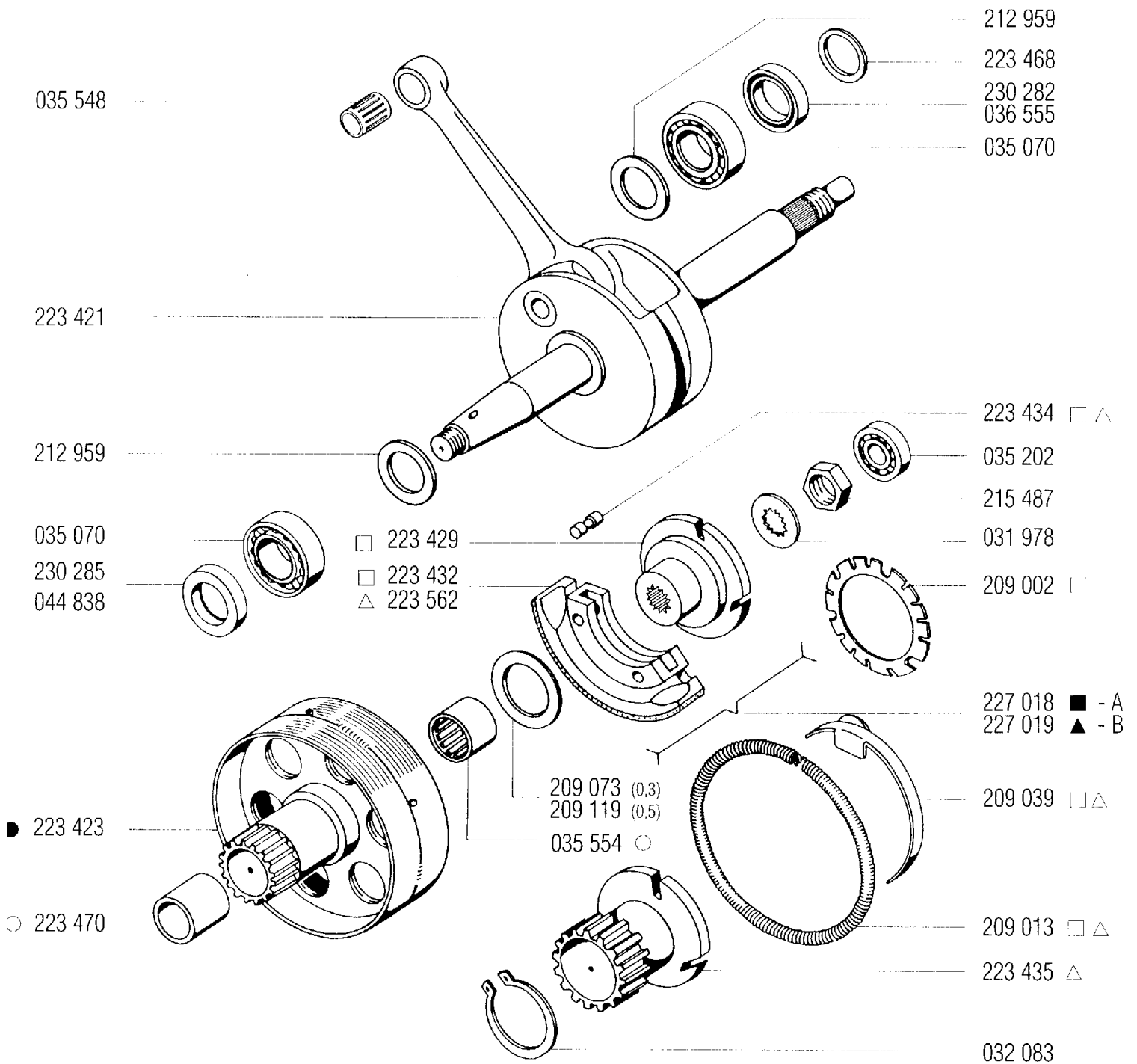

A - 1st speed clutch
 B - 2nd speed clutch

COUNTERSCHAFT, MAINSHAFT

C

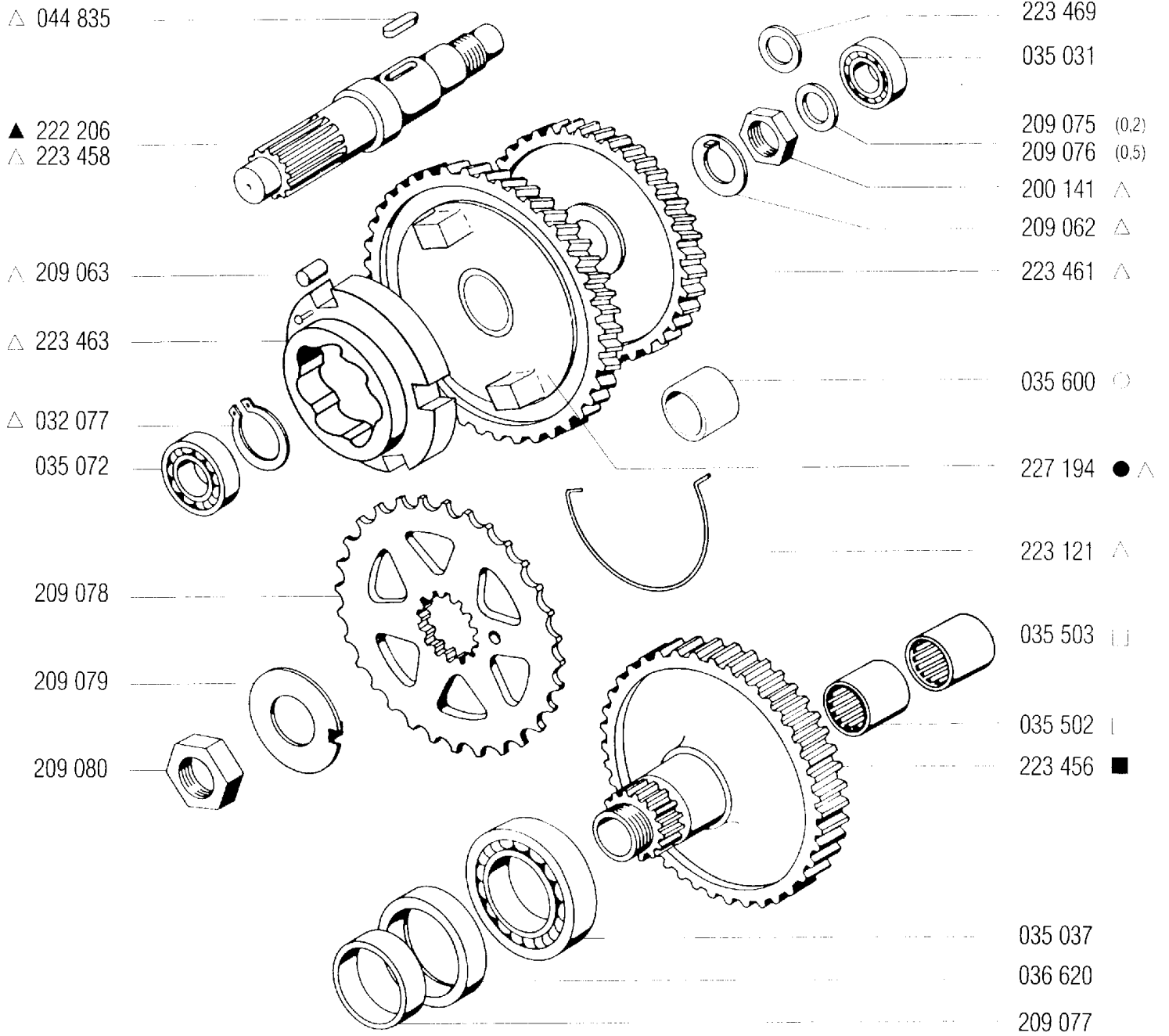

△ 222 209 (section D)

STARTER ASSEMBLY

D

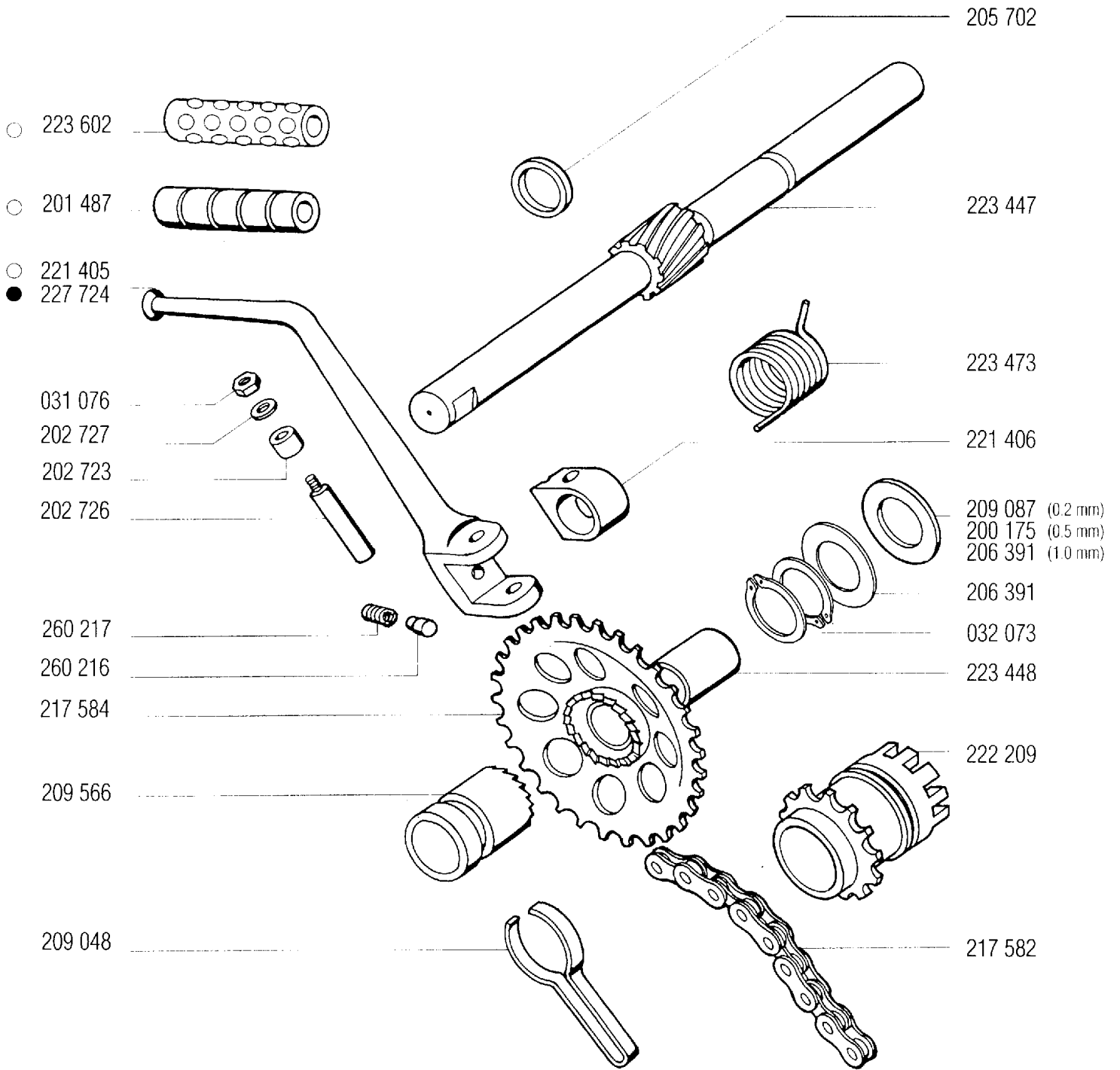

MAGNETO ASSEMBLY

E

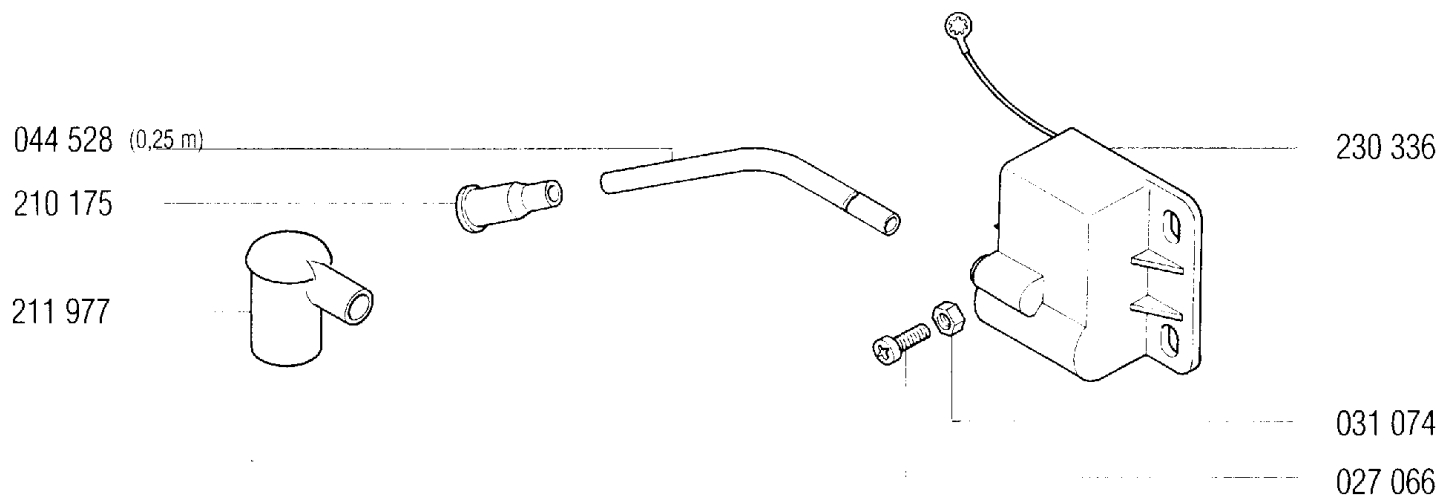
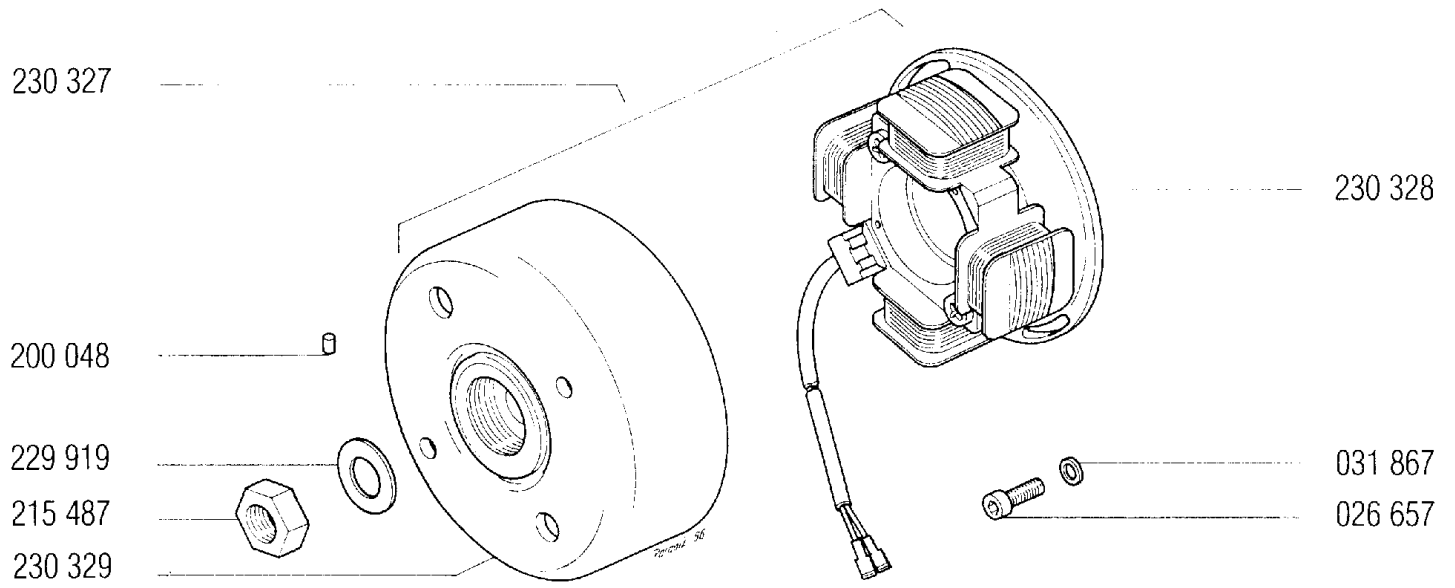

CARBURETOR, INTAKE MANIFOLD

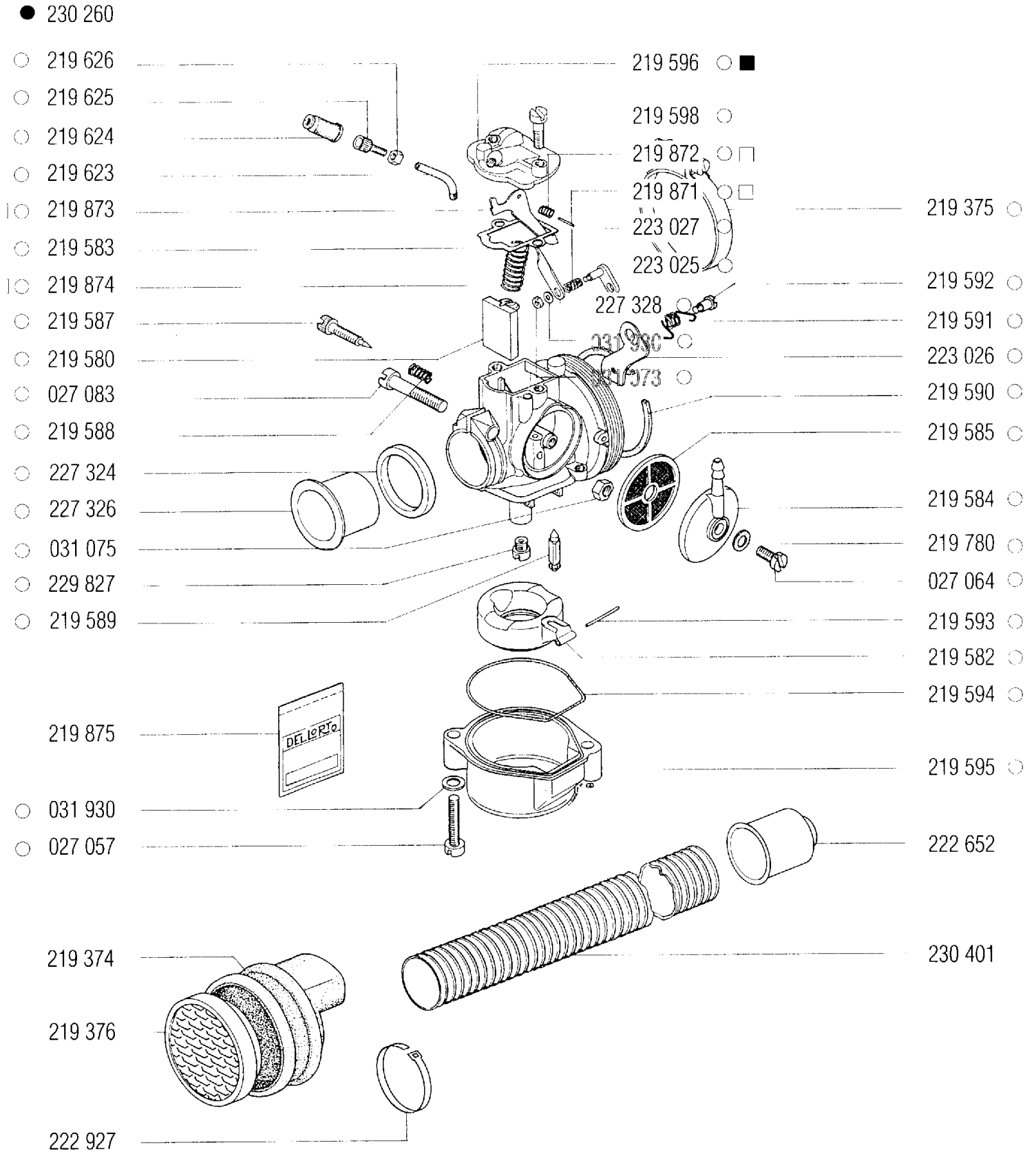

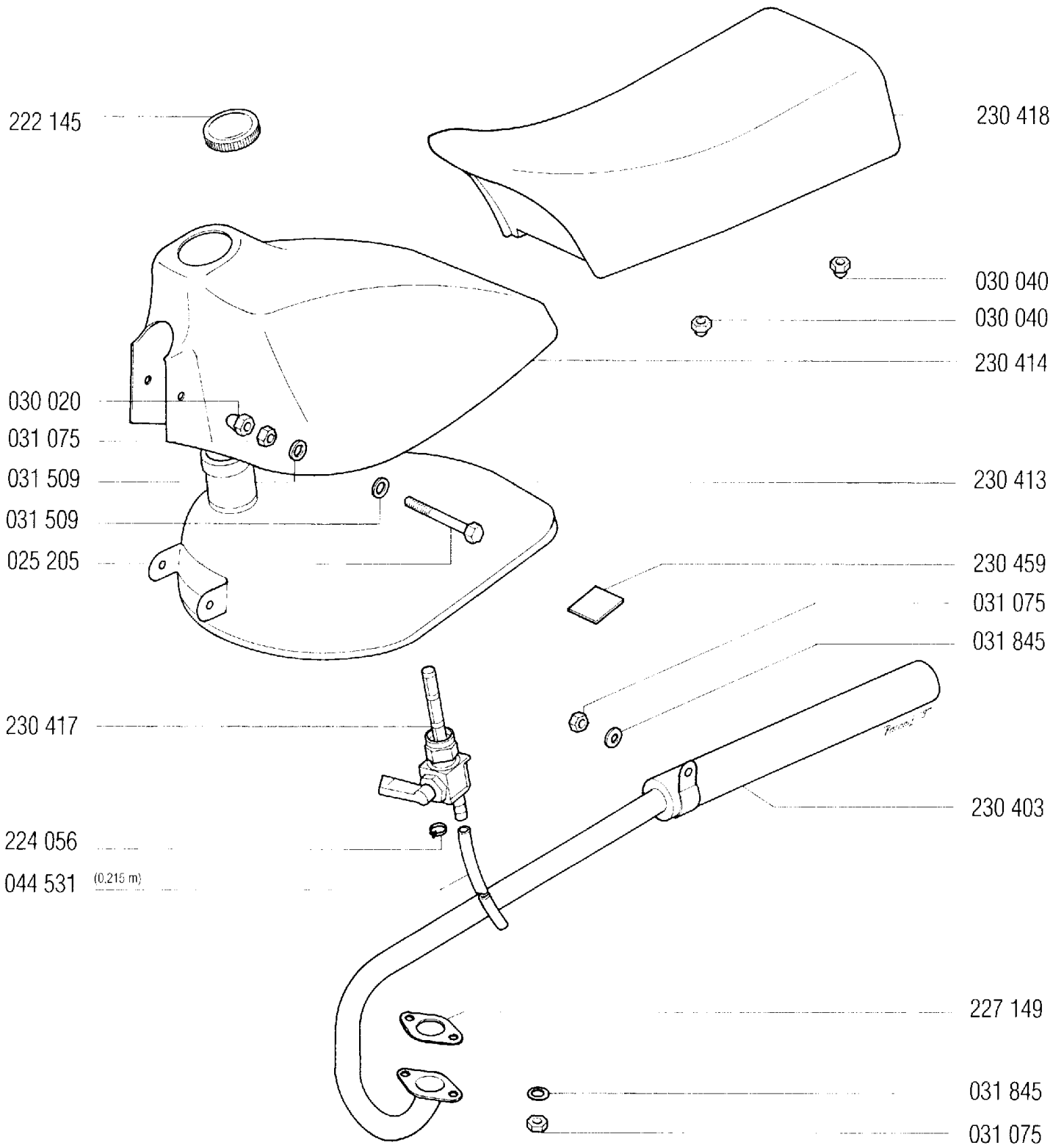

FRAME, SWING ARM

H

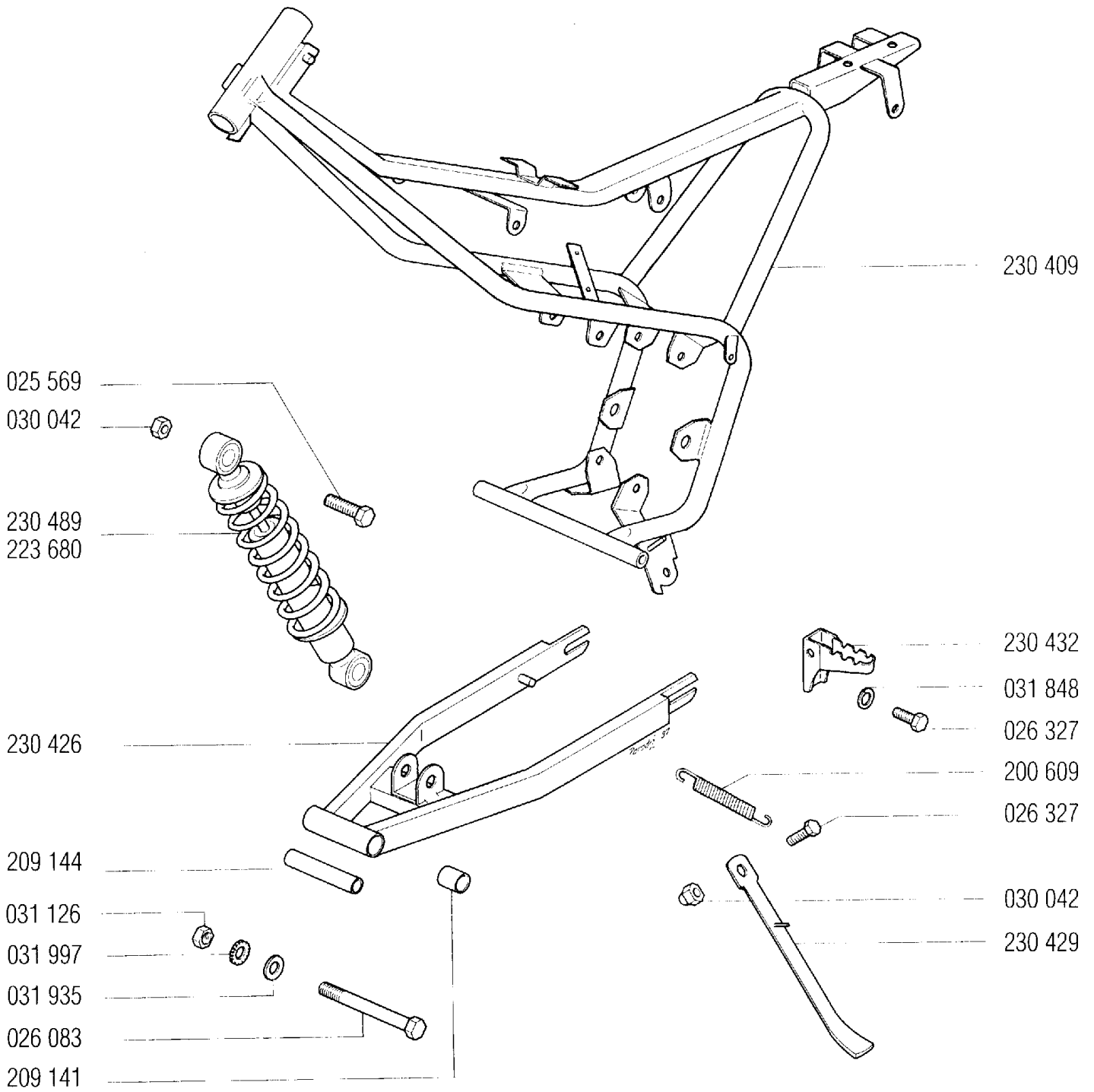

COVERS, FENDERS

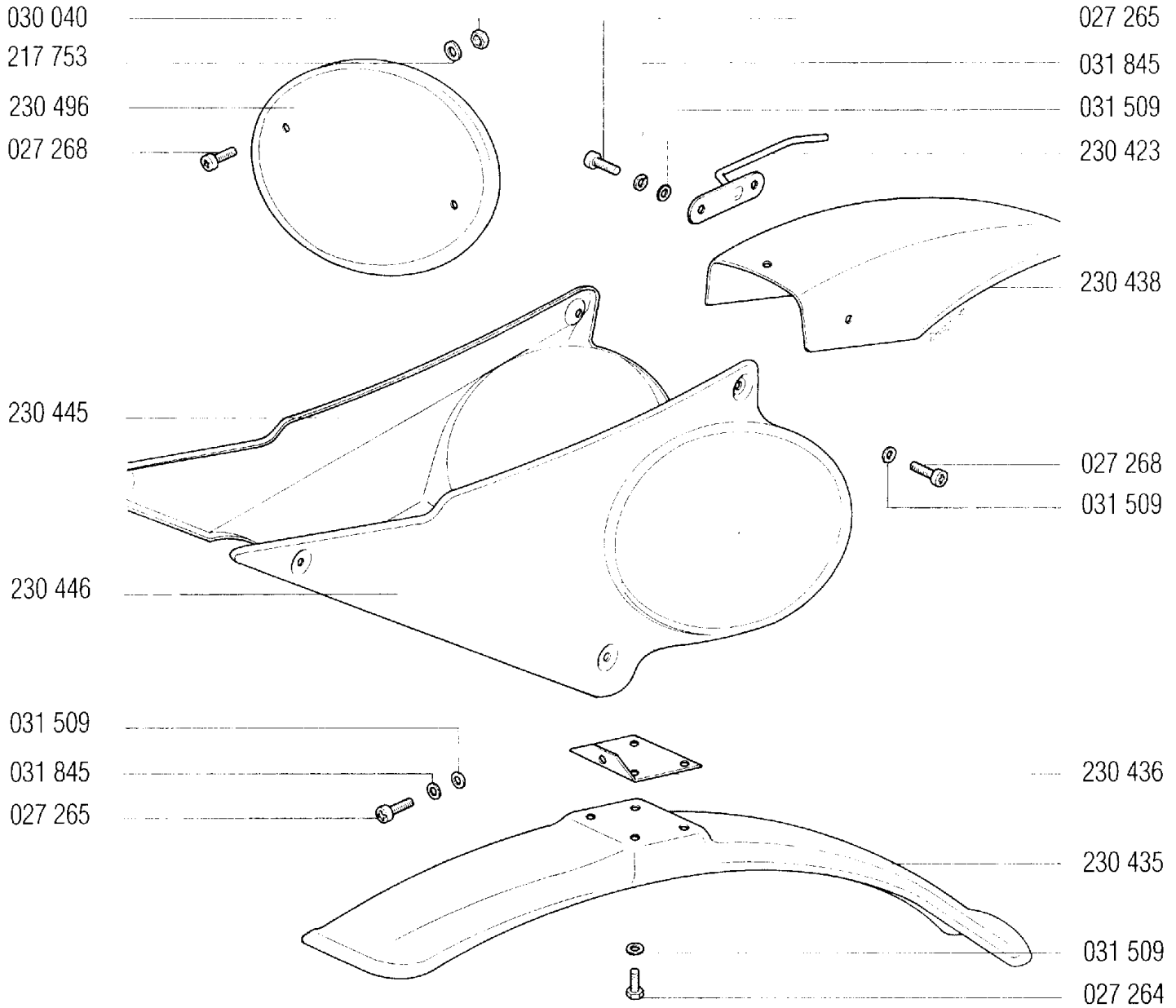

decals	m.1	230 419 (grey, green, blue, ultra-marine blue, red)
	m.2	230 421 (red)

FRONT FORKS

J

▲ 227 470 - set of bearings

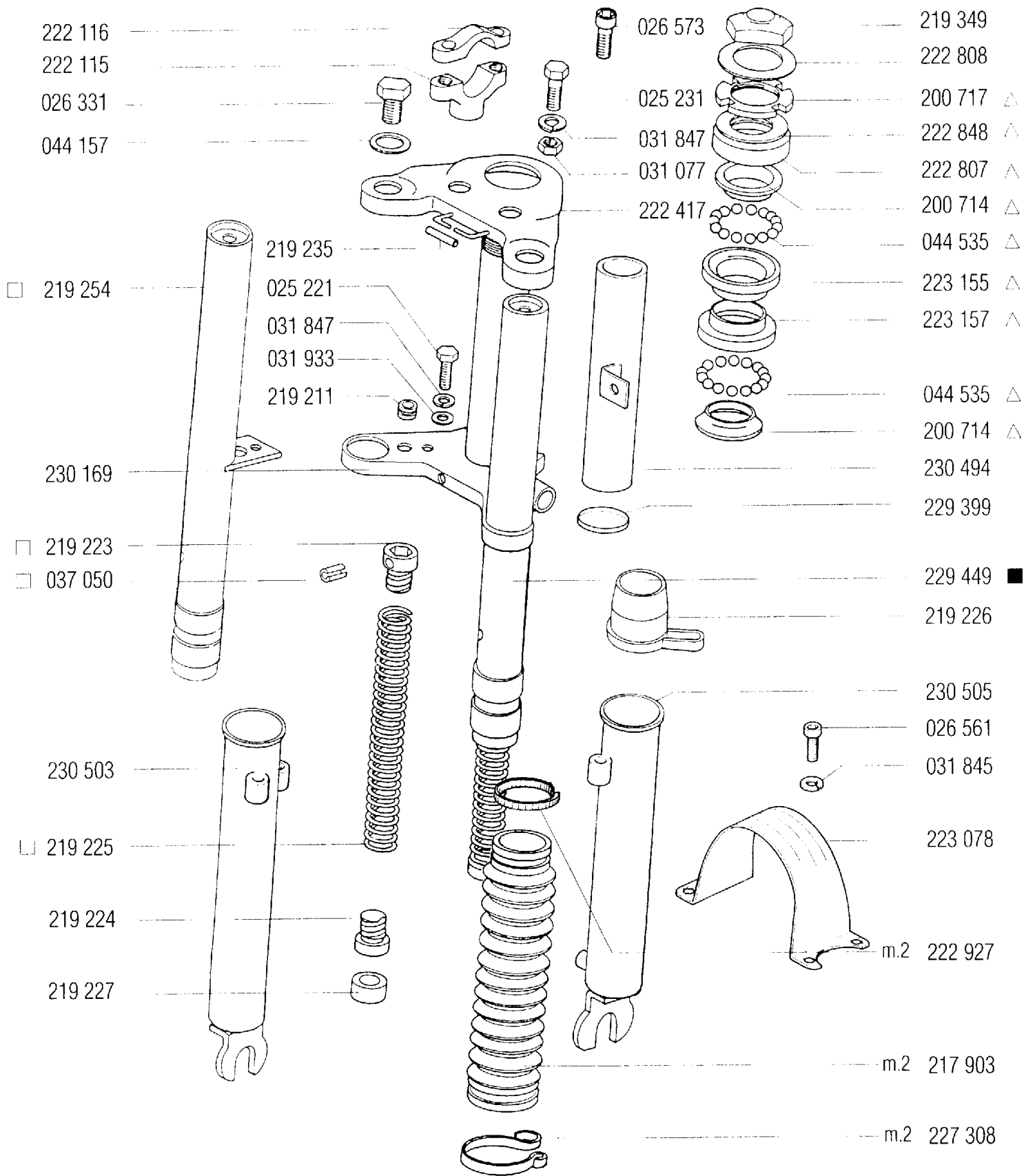

- 229 551 - throttle assy.
- 229 552 - rear brake lever assy.

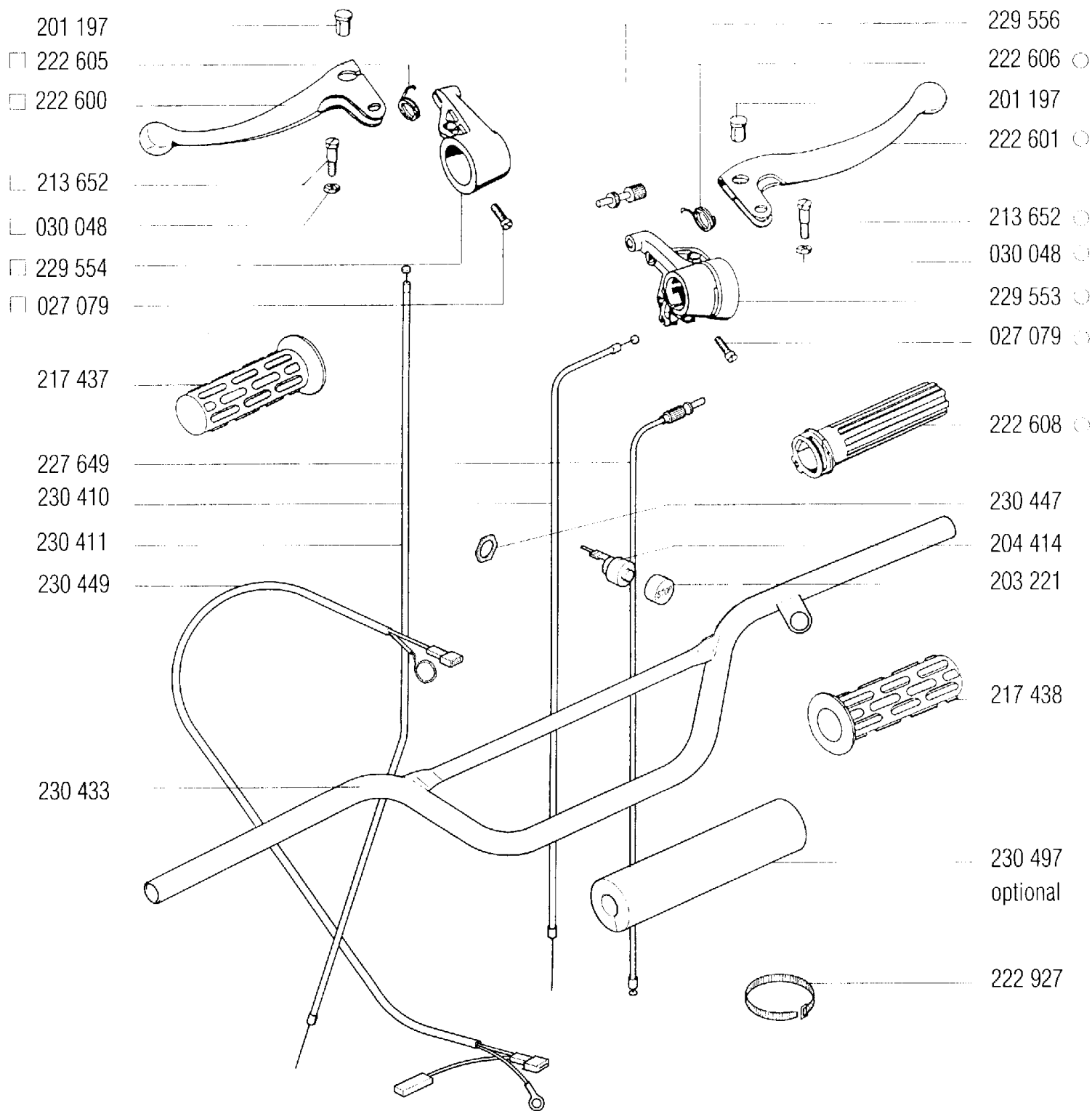

- 201 197
- 222 605
- 222 600
- L 213 652
- L 030 048
- 229 554
- 027 079
- 217 437
- 227 649
- 230 410
- 230 411
- 230 449
- 230 433

- 229 556
- 222 606 ○
- 201 197
- 222 601 ○
- 213 652 ○
- 030 048 ○
- 229 553 ○
- 027 079 ○
- 222 608 ○
- 230 447
- 204 414
- 203 221
- 217 438
- 230 497
optional
- 222 927

● 230 517

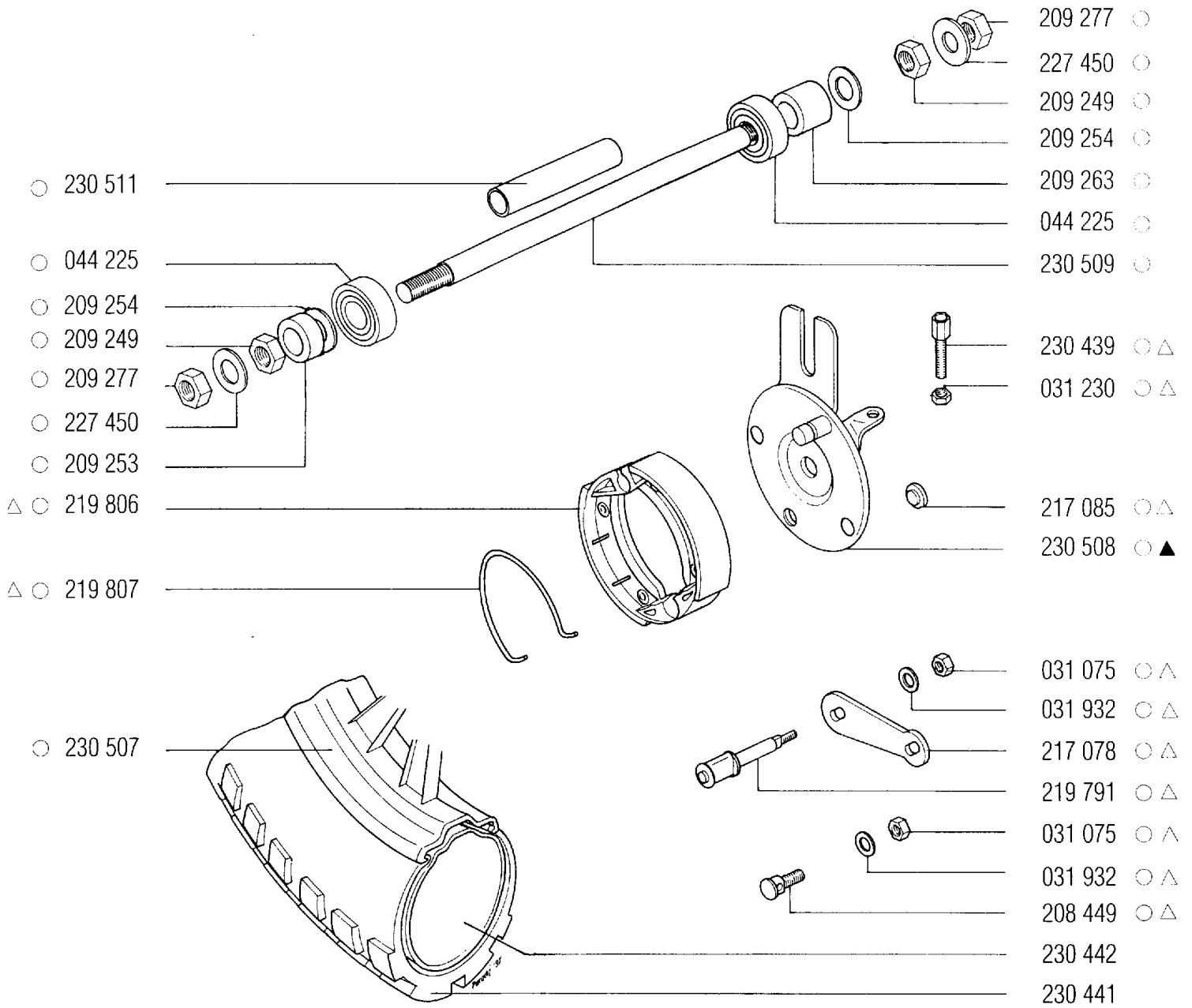

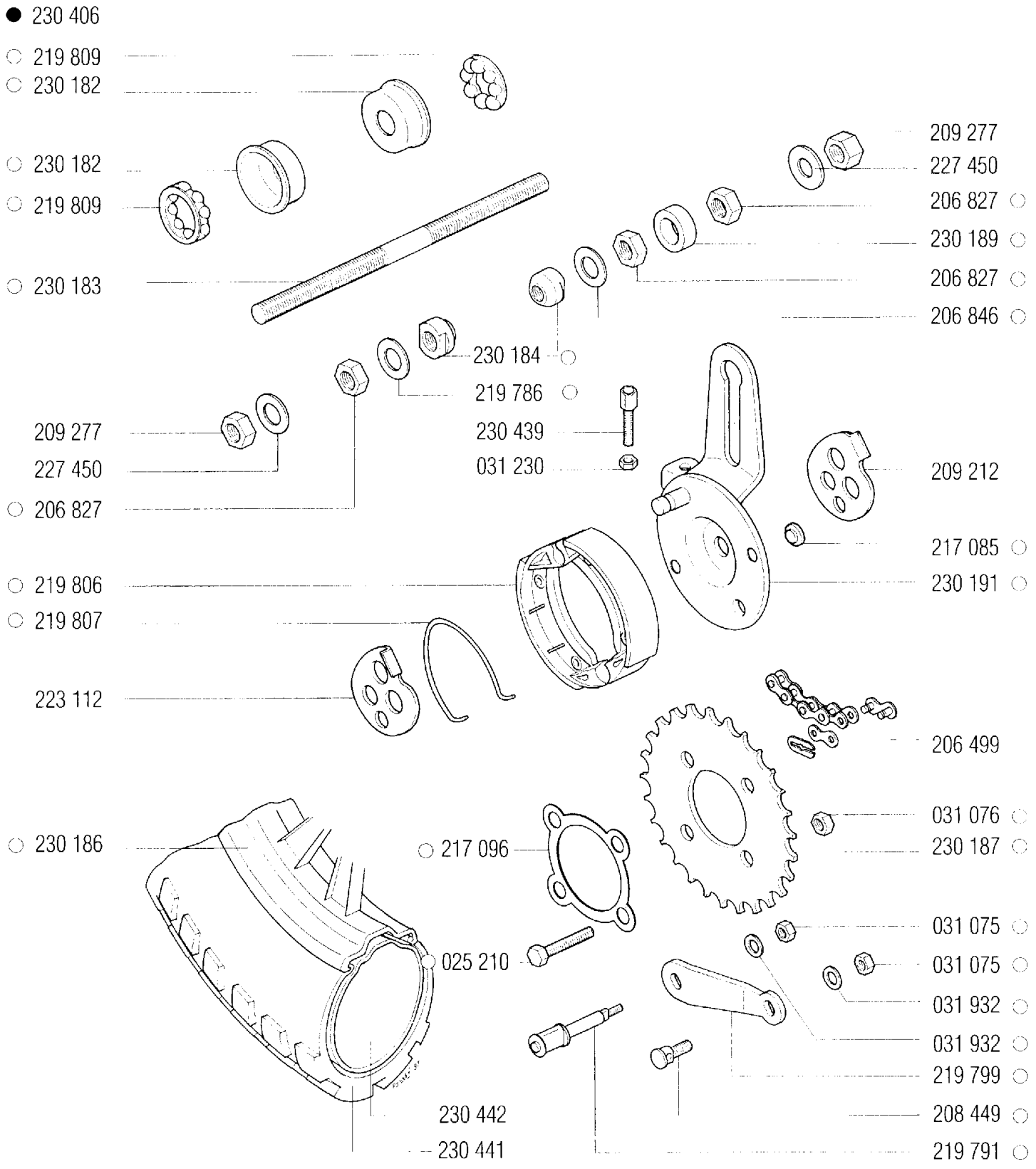

● 230 518

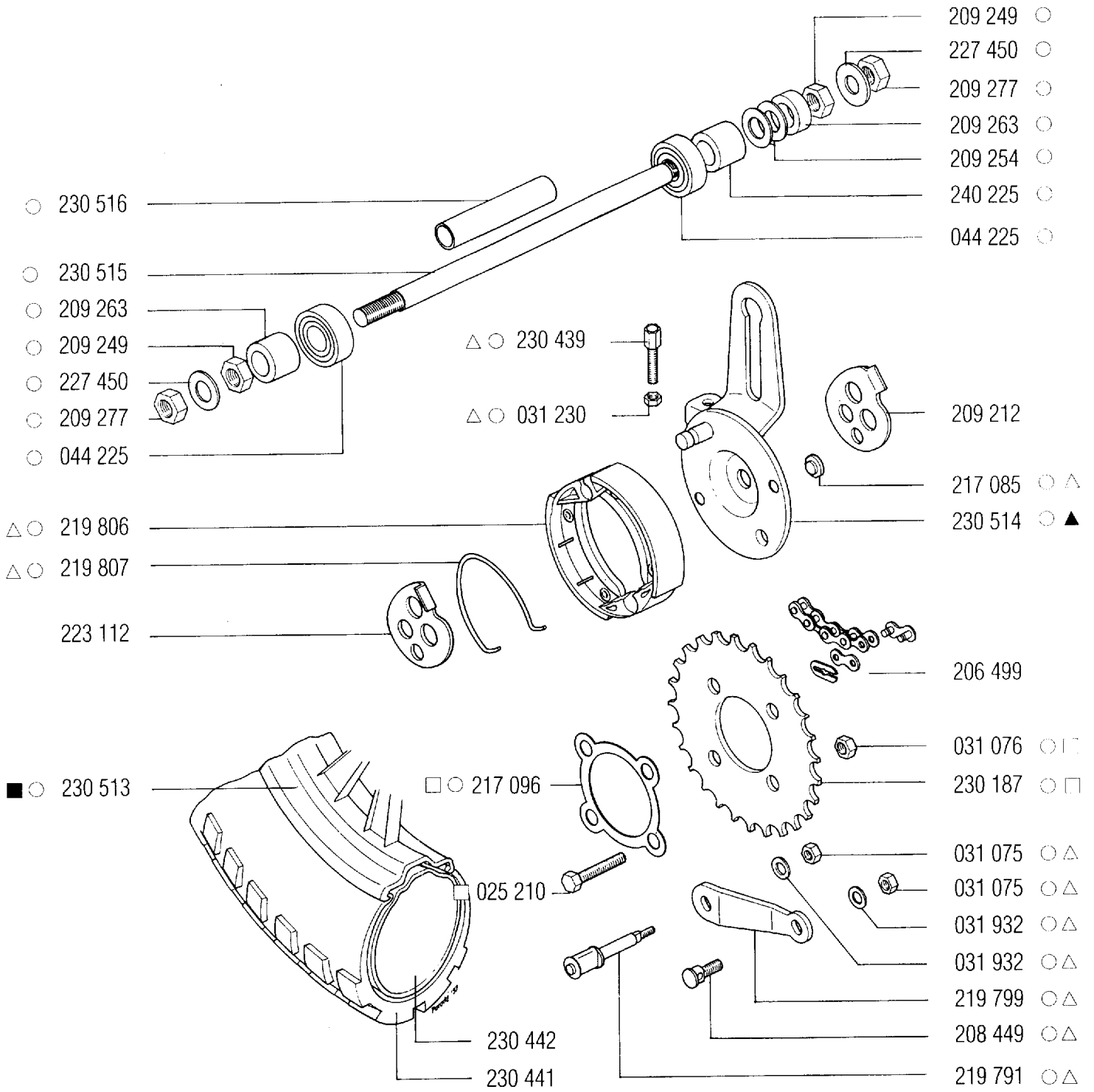

RING	C	219234	SUPPORTING TUBE
RING	B	219349	STEERING NUT
TCH	B	219374	JUNCTION SLEEVE
	C	219375	CLAMP
	B	219376	AIR FILTER
	C	219580	THROTTLE SLIDE
	J	219582	FLOAT
	A	219583	GASKET
G 6201-2	J	219584	FUEL CONNECTION
	L, M	219585	FUEL FILTER
	A	219587	ADJUSTING CREW
	E, Ea	219588	SPRING
	G	219589	FLOAT VALVE
(FY	J	219590	GASKET
	C	219591	SPRING
	B	219592	SCREW
	E, Ea	219593	FLOAT PIN
	C	219594	GASKET
n)	D	219595	FLOAT CHAMBER
	A	219596	COVER
	H	219598	SCREW
ARING CONE	J	219623	CONNECTION
SH	F	227334	PISTON 1st OVERSIZE
SCREW	F	227450	WASHER D11 1xD20x2
	F	227470	SET OF HANDLEBAR BEARING
	F	227501	GUDGEON PIN
ASHER	L, M	227649	THROTTLE CABLE
	L, M	227724	KICK START LEVER
3	M	227758	PISTON RING
	L, M	229399	RUBBER RING
	L, M	229402	CYLINDER WITH PISTON
(GE)	L, M	229444	MAGNETO CPL.
	F	229445	ELECTRONIC IGNITION COIL
	F	229449	SUPPORTING TUBE
	F	229483	COIL
	F	229484	FLYWHHEEL
(FT	F	229485	DISTANCE BUSH
LEVER	D	229551	THROTTLE ASSY.
	D	229552	BRAKE LEVER
	A	229553	LEVER CLAMP RH
GASKET	A	229554	LEVER CLAMP LH
GASKET	A	229556	ADJUSTING SCREW
LEBAR CLAMP	J	229827	MAIN JET
LEBAR CLAMP	J	229919	WASHER
	G	230156	ENGINE
AFT	C	230169	LOWER YOKE
(GE	C, D	230172	SEALING WASHER A6x12
	A	230173	SCREW A8x14
JG	J	230182	RING
3 LH	K	230183	REAR AXLE
3 RH	K	230184	STEERING BEARING CONE
	K	230186	REAR WHEEL
	K	230187	REAR WHEEL